

DESCRIPTION

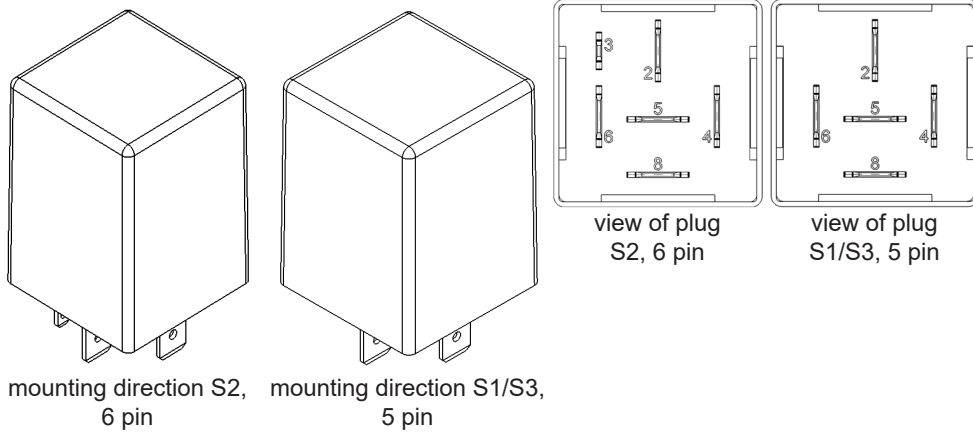

The controller M3 is a powerful and cost-effective controller. In addition to the unprogrammed control M3 there is the control in the programmed versions: Pulse relay, step switch relay, blinker as well as other functions on request.

TECHNICAL DATA

Housing	Plastic PA66GF30
Connector	Base plate 5/6 pin (depending on assembly)
Weight	45 g
Temperature range acc. to ISO 16750-4	-40 °C...+85 °C (at +85 °C not full load)
Environmental protection acc. to ISO 20653	IP 6K8, when using the waterproof plug-in socket and correct installation position (plug vertically downwards)
Current consumption	2 ± 1 mA + load (higher with negative edge triggering, since the relay picks up directly after switching on)
Quiescent current	not available
Over-current Protection	1 A + load
Total Inputs and outputs	1 switching input / 1 relays output (2)
Input	Digital, positive encoder signals
Output	1 relay output (NO, NC)
Supply voltage	Depending on assembly, see supply voltage range from p. 5
Overvoltage protection	no
Reverse polarity protection	yes
Minimum pulse width switching input	30 ms

REGULATORY APPROVALS AND TESTING

E1 approval	10 R - 05 7282
Electrical tests	Acc. to ISO 16750-2 or -4: Short circuit protection Jump-start (12 V modules) Reverse polarity test Pin/connector interruption Storage test at T _{max} and T _{min} Operation test at T _{max} and T _{min}
	Acc. to ISO 7637-2: Pulse 1, 2a, 2b, 3a, 3b
Chemical tests	Acc. to ISO 16750-5: AA, AB, AC, BA, BB, BC, BD, CA, CB, CC, CD, DB, DC, DD, DF, DG, DJ, DK, EA, EB, EC, ED, EF

SOFTWARE/PROGRAMMING

Programming system MRS Realizer

The programming tool MRS Realizer is the suitable software for the simple and fast programming of the MRS controllers M1, M3, Micro SPS and the MRS proportional amplifier. The parameterization is done in an uncomplicated way via the relay contacts, thus saving you valuable time for opening the housing. Easily create your own programs for your application via the Z-graph. Graphical function blocks (based on IEC61131) are available in EAGLE for this purpose. You can download the new AUTODESK EAGLE version according to your needs and requirements at:
<http://www.autodesk.com/products/eagle/overview>.

PIN ASSIGNMENT POWER SUPPLY AND PROGRAMMING INTERFACES

Pin	Description	Pin	Description
2	Supply voltage (S1) / connection potential-free relay COM (Type S2 depending on assembly)	5	Relais output NC
3	Supply voltage (S2) / analog input	6	GND
4	Programming interface / switching input, Supply voltage (S3)	8	Relais output NO

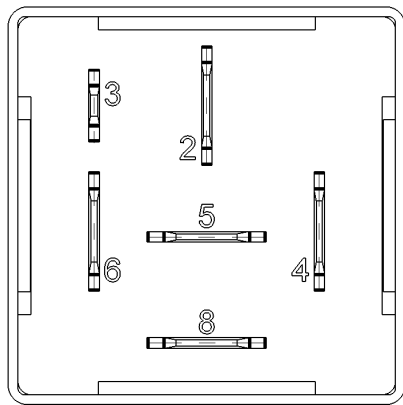

pin assignment S2, 6 pin, bottom view

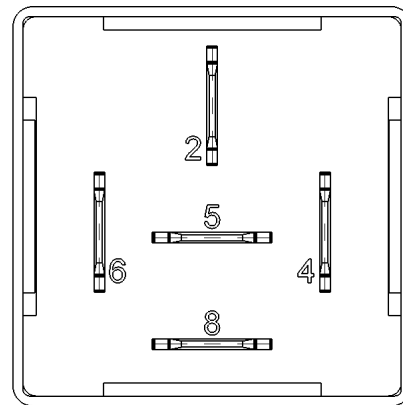

pin assignment S1/S3, 5 pin, bottom view

CONNECTION DIAGRAM

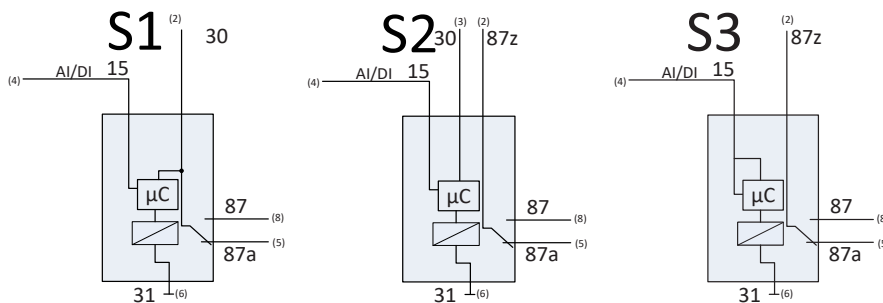

PIN FEATURE MAP

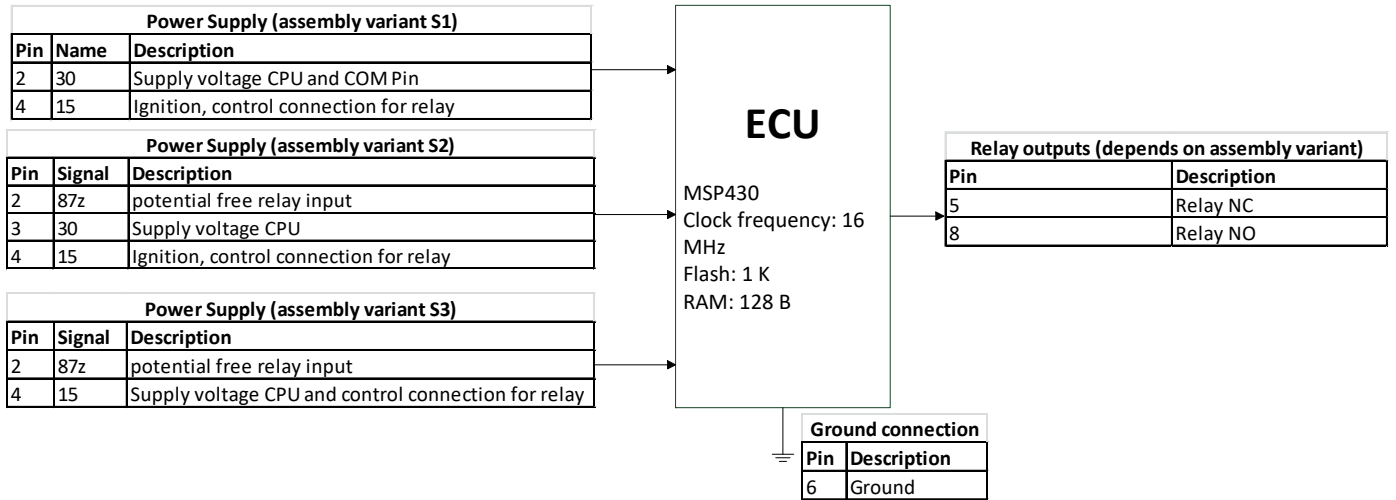

BLOCK FUNCTION DIAGRAM

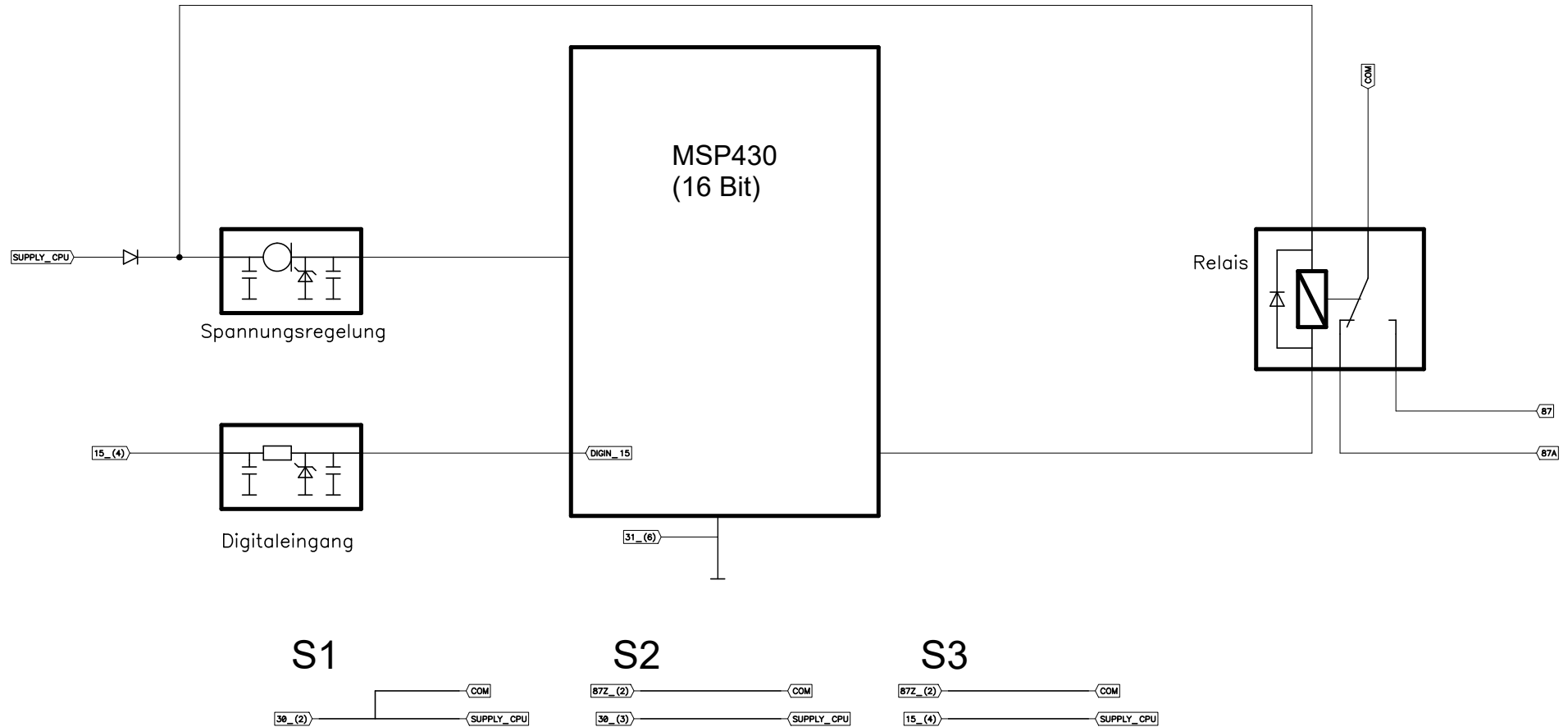

TECHNICAL DRAWING IN MM [INCH], TOLERANCES ACCORDING TO ISO 2768-1 V

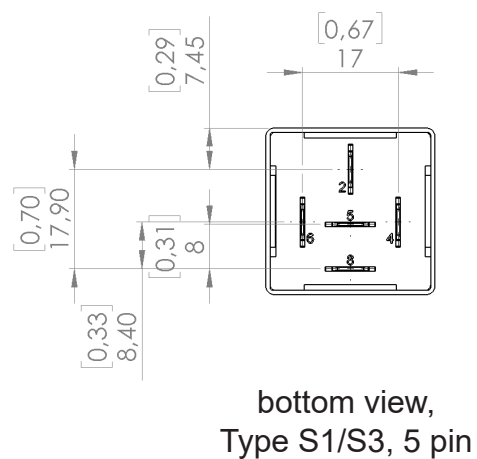
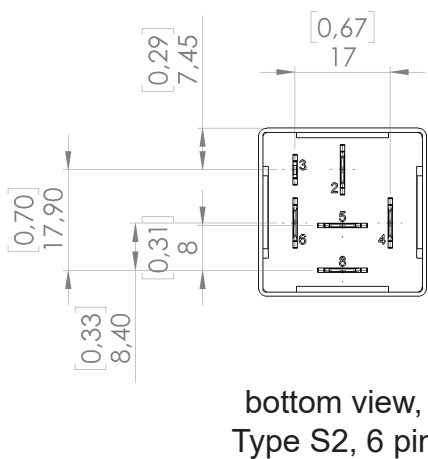
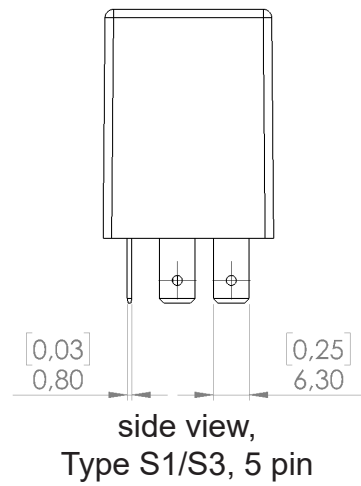
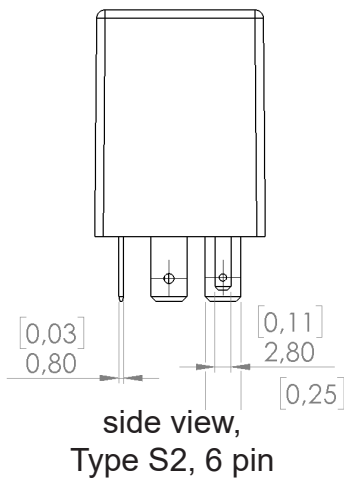
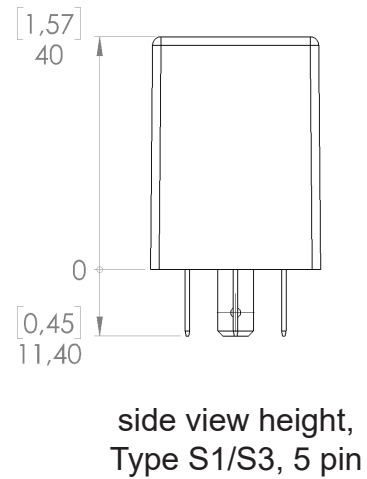
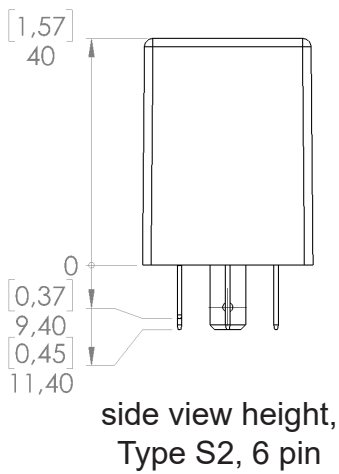
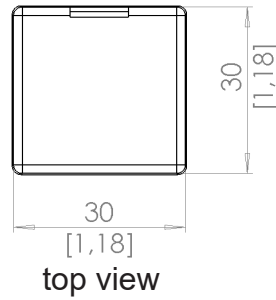

ASSEMBLY OPTIONS AND ORDER INFORMATION M3

Order number	Supply voltage	Supply μ C / Relais	Digital input	Pin assignment of outputs	Max. load output at 85 °C ²	Supply voltage range	Features
	see page 2 and 3	Pin	Pin 4 switching threshold ± 0.5 V ¹	Relay output	Relay output 1. 2s NO/ 2s NC 2. Permanent load		
1.036.101.00	12 V / S1	2 / 2	5.8	5,8	1. 15 A 2. 20A NO/15A NC	9-16 V	
1.036.101.10	12 V / S1	2 / 2	5.8	5,8	1. 15 A 2. 20A NO/15A NC	9-16 V	with negative edge control KL15 ³
1.036.102.00	12 V / S2	3 / 2	5.8	5,8 (potential free)	1. 15 A 2. 20A NO/15A NC	9-16 V	
1.036.102.10	12 V / S2	3 / 2	5.8	5,8 (potential free)	1. 15 A 2. 20A NO/15A NC	9-16 V	with negative edge control KL15 ³
1.036.103.00	12 V / S3	4 / 2	supply voltage	5,8 (potential free)	1. 15 A 2. 20A NO/15A NC	9-16 V	
1.036.201.00	24 V / S1	2 / 2	5.8	5,8	1. 10 A 2. 15A NO/15A NC	14-32 V	
1.036.202.00	24 V / S2	3 / 2	5.8	5,8 (potential free)	1. 10 A 2. 15A NO/15A NC	14-32 V	
1.036.203.00	24 V / S3	4 / 2	supply voltage	5,8 (potential free)	1. 10 A 2. 15A NO/15A NC	14-32 V	

¹ If supply voltage acc. to column 3 is applied // ² with 85°C resistive load

³ with negative edge control, the relay picks up directly during the switch-on cycle, since an edge is detected by switching on the module

ASSEMBLY OPTIONS AND ORDER INFORMATION TIME RELAY M3 SWITCH ON DELAY

Order number	Supply voltage	Supply μC / Relais	Digital input	Pin assignment of outputs	Max. load output at 85 °C ²	Supply voltage range	Features
	see page 2 and 3	Pin	Pin 4 $\pm 0.5 \text{ V}^1$	Relay outputs	Relays outputs 1. 2s NO/ 2s NC 2. Permanent load		
1.003.193.xx	12 V / S3	4 / 2	supply voltage	5,8 (potential free)	1. 15 A 2. 20A NO/15A NC	9-16 V	When ordering, please specify individual delay time (example: 5 seconds)
1.003.194.xx	12 V / S1	2 / 2	5.8	5,8	1. 15 A 2. 20A NO/15A NC	9-16 V	
1.003.195.xx	12 V / S2	3 / 2	5.8	5,8 (potential free)	1. 15 A 2. 20A NO/15A NC	9-16 V	
1.003.293.xx	24 V / S3	4 / 2	supply voltage	5,8 (potential free)	1. 10 A 2. 15A NO/15A NC	14-32 V	
1.003.294.xx	24 V / S1	2 / 2	5.8	5,8	1. 10 A 2. 15 A NO/15A NC	14-32 V	
1.003.295.xx	24 V / S2	3 / 2	5.8	5,8 (potential free)	1. 10 A 2. 15 A NO/15A NC	14-32 V	

¹ If supply voltage acc. to column 2 is applied // ² with 85°C resistive load

FUNCTION DIAGRAM TIME RELAIS M3 SWITCH ON DELAY

If the voltage is set at terminal 15, the relay will pull on at the end of the specified time. If the voltage is removed at terminal 15, the relay immediately drops off.

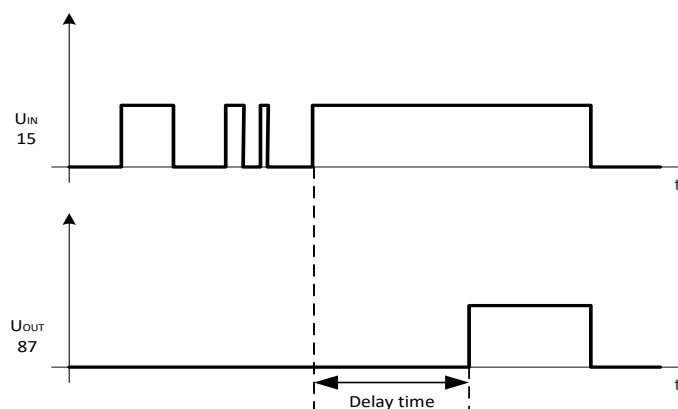

ASSEMBLY OPTIONS AND ORDER INFORMATION TIME RELAY M3 SWITCH OFF DELAY

Order number	Supply voltage	Supply μ C / Relais	Digital input	Pin assignment of outputs	Max. load output ²	Supply voltage range	Features
	see page 2 and 3	Pin	Pin 4 ± 0.5 V ¹	Relay outputs	Relay outputs 1. 2s NO/ 2s NC 2. Permanent load		
1.003.191.xx	12 V / S1	2 / 2	5.8	5,8	1. 15 A 2. 20A NO/15A NC	9-16 V	When ordering, please specify individual delay time (example: 5 seconds)
1.003.192.xx	12 V / S2	3 / 2	5.8	5,8 (potential free)	1. 15 A 2. 20A NO/15A NC	9-16 V	
1.003.291.xx	24 V / S1	2 / 2	5.8	5,8	1. 10 A 2. 15 A NO/15A NC	14-32 V	
1.003.292.xx	24 V / S2	3 / 2	5.8	5,8 (potential free)	1. 10 A 2. 15 A NO/15A NC	14-32 V	

¹ If supply voltage acc. to column 2 is applied // ² with 85°C resistive load

FUNCTION DIAGRAM TIME RELAY M3 SWITCH OFF DELAY

If the voltage is set at terminal 15, the relay will pull on at the end of the specified time. If the voltage is removed at terminal 15, the relay immediately drops off.

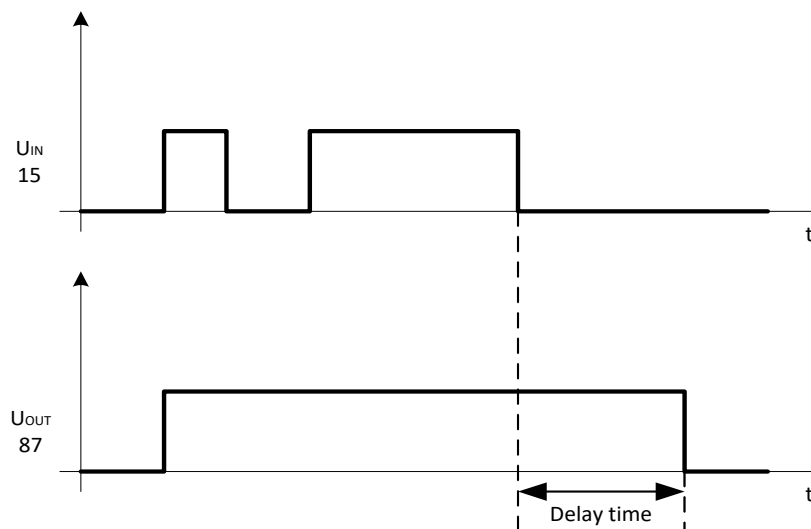

ASSEMBLY OPTIONS AND ORDER INFORMATION TIME RELAY M3 SWITCH ON AND OFF DELAY

Order number	Supply voltage	Supply μ C / Relais	Digital input	Pin assignment of outputs	Max. load output ²	Supply voltage range	Features
	see page 2 and 3	Pin	Pin 4 ± 0.5 V ¹	Relay output	Relay outputs 1. 2s NO/ 2s NC 2. permanent load		
1.003.196.xx	12 V / S1	2 / 2	5.8	5,8	1. 15 A 2. 20A NO/ 15A NC	9-16 V	When ordering, please specify individual delay time (example: 5 seconds)
1.003.197.xx	12 V / S2	3 / 2	5.8	5,8 (potential free)	1. 15 A 2. 20A NO/ 15A NC	9-16 V	
1.003.296.xx	24 V / S1	2 / 2	5.8	5,8	1. 10 A 2. 15A NO/ 15 A NC	14-32 V	
1.003.297.xx	24 V / S2	3 / 2	5.8	5,8 (potentil free)	1. 10 A 2. 15A NO/ 15 A NC	14-32 V	
1.003.298.xx	24 V / S2	3 / 2	5.8	5,8 (potentil free)	1. 10 A 2. 15A NO/ 15 A NC	14-32 V	
							negative edge control KL15 ³

¹ If supply voltage acc. to column 2 is applied (pickup voltage relay) // ² with 85°C resistive load

³ with negative edge control, the relay picks up directly during the switch-on cycle, as an edge is detected by switching on the module

FUNCTION DIAGRAM TIME RELAY M3 SWITCH ON AND OFF DELAY

If voltage is applied to terminal 15, the relay picks up after the specified time has elapsed. If the voltage is removed from terminal 15, the relay drops out after the specified time has elapsed.

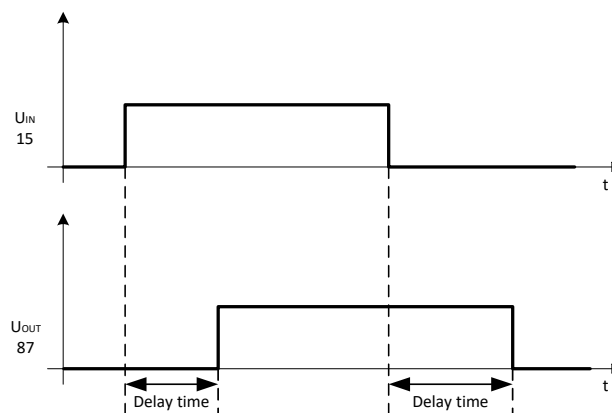

ASSEMBLY OPTIONS AND ORDER INFORMATION PULSE RELAY M3

Order number	Supply voltage	Supply μC / Relais	Digital input	Pin assignment of outputs	Max. load output ²	Supply voltage range	Features
	see page 2 and 3	Pin	Pin 4 $\pm 0.5 \text{ V}^1$	Relay outputs	Relay outputs 1. 2s NO/ 2s NC 2. permanent load		
1.002.191.xx	12 V / S1	2 / 2	5.8	5,8	1. 15 A 2. 20 A NO/15 A NC	9-16 V	When ordering, please specify individual pulse time (example: 5 seconds)
1.002.192.xx	12 V / S2	3 / 2	5.8	5,8 (potential free)	1. 15 A 2. 20 A NO/15 A NC	9-16 V	
1.002.193.xx	12 V / S3	4 / 2	supply voltage	5,8 (potential free)	1. 15 A 2. 20 A NO/15 A NC	9-16 V	
1.002.291.xx	24 V / S1	2 / 2	5.8	5,8	1. 10 A 2. 15 A NO/15A NC	14-32 V	
1.002.292.xx	24 V / S2	3 / 2	5.8	5,8 (potential free)	1. 10 A 2. 15 A NO/15A NC	14-32 V	
1.002.293.xx	24 V / S3	4 / 2	supply voltage	5,8 (potential free)	1. 10 A 2. 15 A NO/15A NC	14-32 V	

¹ If supply voltage acc. to column 2 is applied (pickup voltage relay) // ² with 85°C resistive load

FUNCTION DIAGRAM PULSE RELAY M3

Circuit diagram S1 and S2: Supply voltage is applied to terminal 30. If the voltage is set at Terminal 15, the relay will immediately pull in for the specified time and then fall off again. The duration of the control signal has no effect on the output pulse duration (i.e. the relay is not retriggerable). Circuit diagram S3: Supply voltage is applied to terminal 87z. If the voltage is set at Terminal 15, the relay will immediately pull in for the specified time and then fall off again.

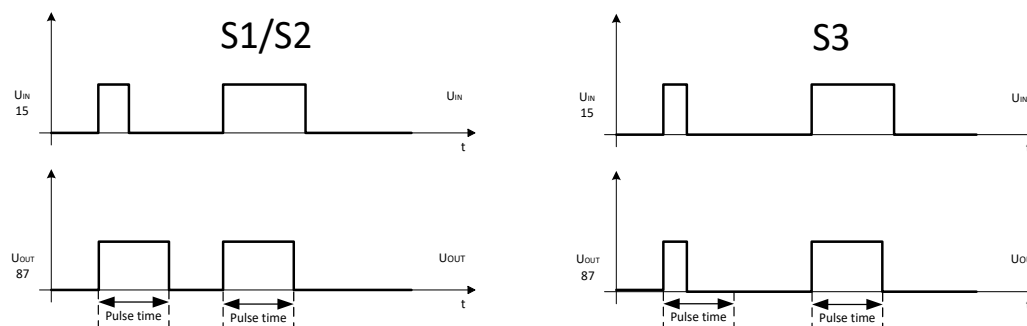

ASSEMBLY OPTIONS AND ORDER INFORMATION TOGGLE RELAY M3

Order number	Supply voltage	Supply μ C / Relais	Digital input	Pin assignment of outputs	Max. load output ²	Supply voltage range	Features
	see page 2 and 3	Pin	Pin 4 ± 0.5 V ¹	Relay outputs	Relay outputs 1. 2s NO/ 2s NC 2. permanent load		
1.001.191.00	12 V / S1	2 / 2	5.8	5,8	1. 15 A 2. 20 A NO/15 A NC	9-16 V	
1.001.192.00	12 V / S1	2 / 2	5.7	5,8	1. 25 A 2. 25 A NO/25 A NC	9-16 V	negative edge control KL15 ³
1.001.193.00	12 V / S2	3 / 2	5.8	5,8 (potential free)	1. 15 A 2. 20 A NO/15 A NC	9-16 V	
1.001.194.00	12 V / S2	3 / 2	5.7	5,8 (potential free)	1. 25 A 2. 25 A NO/25 A NC	9-16 V	negative edge control KL15 ³
1.001.291.00	24 V / S1	2 / 2	5.8	5,8	1. 10 A 2. 15 A NO/15A NC	14-32 V	
1.001.292.00	24 V / S1	2 / 2	5.7	5,8	1. 12 A 2. 25 A NO/25 A NC	14-32 V	negative edge control KL15 ³
1.001.293.00	24 V / S2	3 / 2	5.8	5,8 (potential free)	1. 10 A 2. 15 A NO/15A NC	14-32 V	
1.001.294.00	24 V / S2	3 / 2	5.7	5,8 (potential free)	1. 12 A 2. 25 A NO/25 A NC	15-32 V	negative edge control KL15 ³

¹ If supply voltage acc. to column 2 is applied (pickup voltage relay) // ² with 85°C resistive load

³ with negative edge control, the relay picks up directly during the switch-on cycle, as an edge is detected by switching on the module

FUNCTION DIAGRAM TOGGLE RELAY M3

Circuit diagram S1: With the step switching relay a consumer can be switched via a button. If a positive/negative impulse is applied to Terminal 15, the relay switches and holds itself. Another impulse is switched on again (Power surge switch or toggle flip-flop). The terminal 15 is debounced.

Circuit diagram S2: The contacts are separate from the control and can therefore be used in links. In this variant, the relay contact is completely potential-free and thus capable of switching alternating voltage.

FUNCTION DIAGRAM TOGGLE RELAY M3

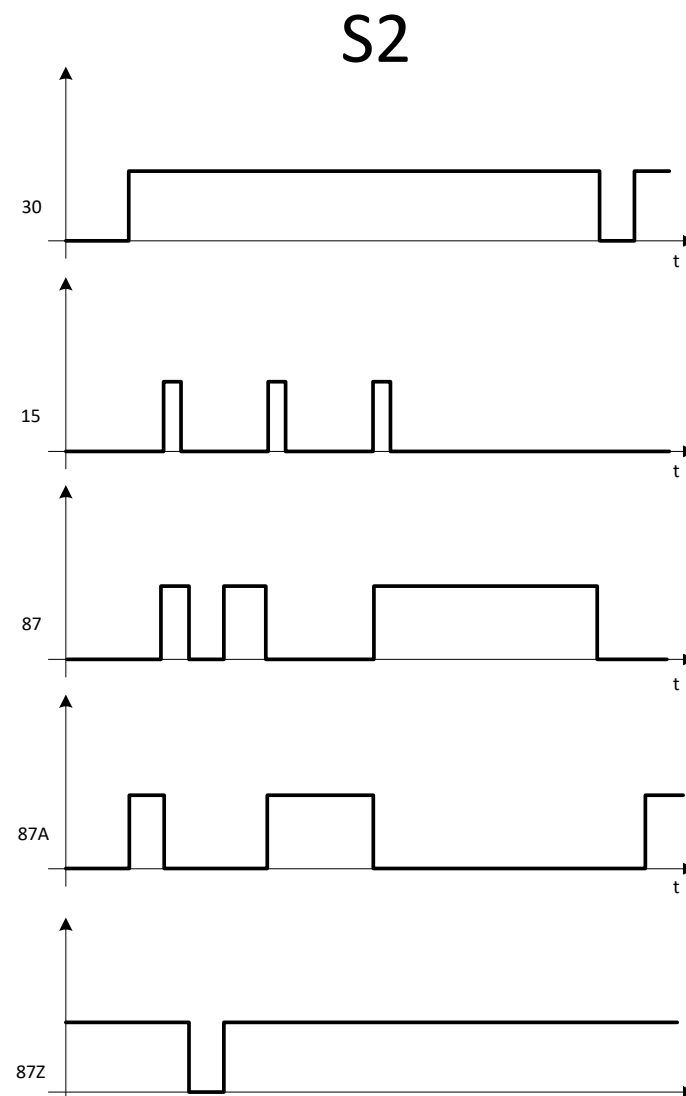
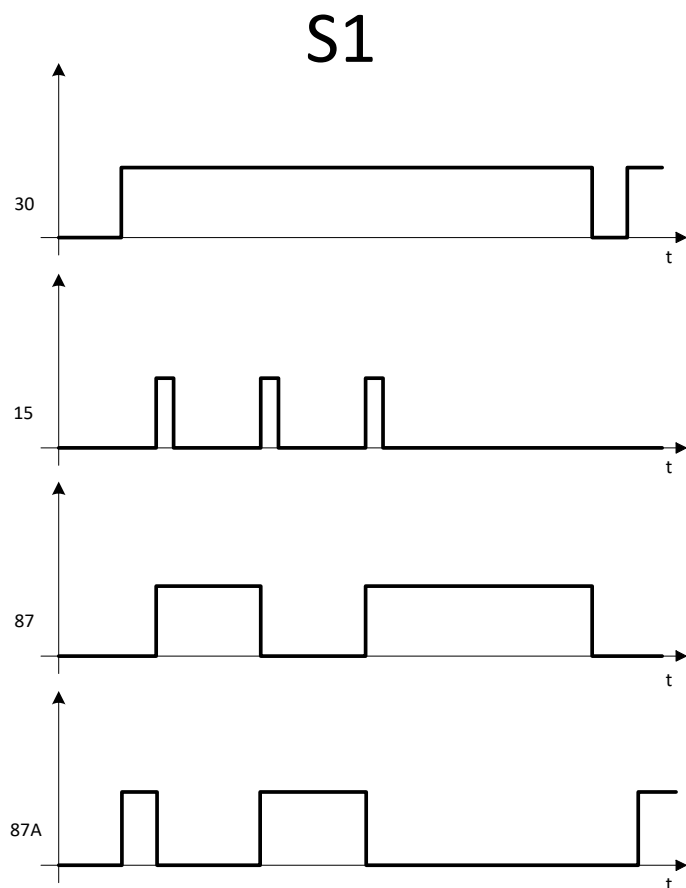

ASSEMBLY OPTIONS AND ORDER INFORMATION TOGGLE RELAY TIME LIMITED M3

Order number	Supply voltage	Supply μ C / Relais	Digital input	Pin assignment of outputs	Max. load output ²	Supply voltage range	Features
	see page 2 and 3	Pin	Pin 4 ± 0.5 V ¹	Relais outputs	Relais outputs 1. 2s NO/ 2s NC 2. permanent load		
1.001.191.xx	12 V / S1	2 / 2	5.8	5,8	1. 15 A 2. 20 A NO/15 A NC	9-16 V	
1.001.192.xx	12 V / S1	2 / 2	5.9	5,8	1. 25 A 2. 25 A NO/25 A NC	9-16 V	negative edge control KL15 ³
1.001.193.xx	12 V / S2	3 / 2	5.8	5,8 (potential free)	1. 15 A 2. 20 A NO/15 A NC	9-16 V	
1.001.194.xx	12 V / S2	3 / 2	5.6	5,8 (potential free)	1. 25 A 2. 25 A NO/25 A NC	9-16 V	negative edge control KL15 ³
1.001.291.xx	24 V / S1	2 / 2	5.8	5,8	1. 10 A 2. 15 A NO/15 A NC	14-32 V	
1.001.292.xx	24 V / S1	2 / 2	5.7	5,8	1. 12 A 2. 25 A NO/25 A NC	15-32 V	negative edge control KL15 ³
1.001.293.xx	24 V / S2	3 / 2	5.8	5,8 (potential free)	1. 10 A 2. 15 A NO/15 A NC	14-32 V	
1.001.294.xx	24 V / S2	3 / 2	5.5	5,8 (potential free)	1. 12 A 2. 25 A NO/25 A NC	15-32 V	negative edge control KL15 ³

¹ If supply voltage acc. to column 2 is applied (pickup voltage relay) // ² with 85°C resistive load

³ With negative edge control, the relay picks up directly during the switch-on cycle, since an edge is detected by switching on the module

FUNCTION DIAGRAM TOGGLE RELAY LIMITED M3

Circuit diagram S1: With the step switching relay a consumer can be switched via a button. If a positive/negative impulse is applied to Terminal 15, the relay switches and holds itself. Another impulse is switched on again (Power surge switch or toggle flip-flop). The terminal 15 is debounced.

Circuit diagram S2: The contacts are separate from the control and can therefore be used in links. In this variant, the relay contact is completely potential-free and thus capable of switching alternating voltage.

FUNCTION DIAGRAM TOGGLE RELAY LIMITED M3

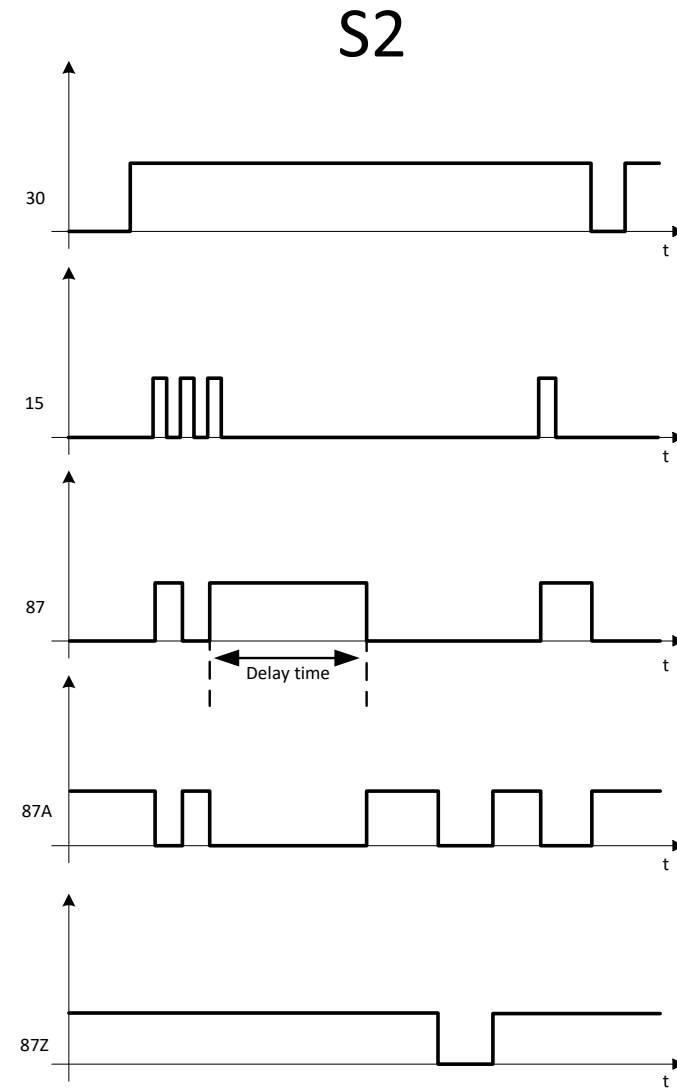
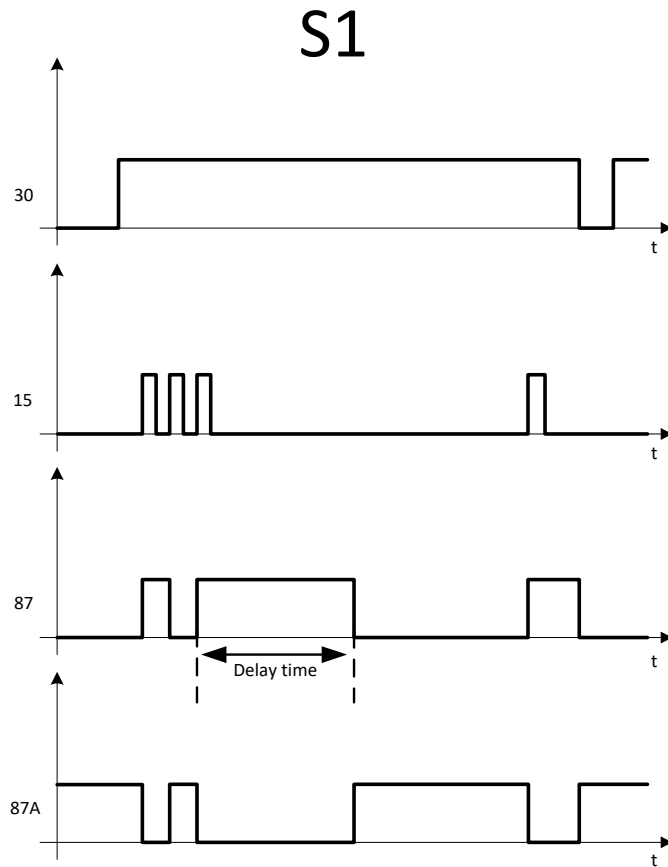

ASSEMBLY OPTIONS AND ORDER INFORMATION FLASHER M3

Order number	Supply voltage	Supply μ C / Relais	Digital input	Pin assignment of outputs	Max. load output ²	Supply voltage range	Features
	see page 4 and 5	Pin	Pin 4 ± 0.5 V ¹	Relay outputs	Relay outputs 1. 2s NO/ 2s NC 2. permanent load		
1.007.191.00	12 V / S1	2 / 2	5.8	5,8	1. 15 A 2. 20 A NO/15 A NC	9-16 V	
1.007.192.00	12 V / S2	3 / 2	5.8	5,8 (potential free)	1. 15 A 2. 20 A NO/15 A NC	9-16 V	
1.007.193.00	12 V / S3	4 / 2	supply voltage	5,8 (potential free)	1. 15 A 2. 20 A NO/15 A NC	9-16 V	
1.007.291.00	24 V / S1	2 / 2	5.8	5,8	1. 10 A 2. 15 A NO/15A NC	14-32 V	
1.007.292.00	24 V / S2	3 / 2	5.8	5,8 (potential free)	1. 10 A 2. 15 A NO/15A NC	14-32 V	
1.007.293.00	24 V / S3	4 / 2	supply voltage	5,8 (potential free)	1. 10 A 2. 15A NO/15A NC	14-32 V	

¹ If supply voltage acc. to column 2 is applied (pickup voltage relay) // ² with 85°C resistive load

FUNCTION DESCRIPTION FLASHER M3

All function diagrams: The supply voltage is connected to terminal 30/87z. When an input voltage is applied to terminal 15 the flasher unit starts immediately, generating 90 +/-30 pulses per minute. The flasher output can switch loads up to 20 A. Higher loads may be switched with a second downstream power relay. The inverted input voltage is present on terminal 87a.

FUNCTION DIAGRAMM FLASHER

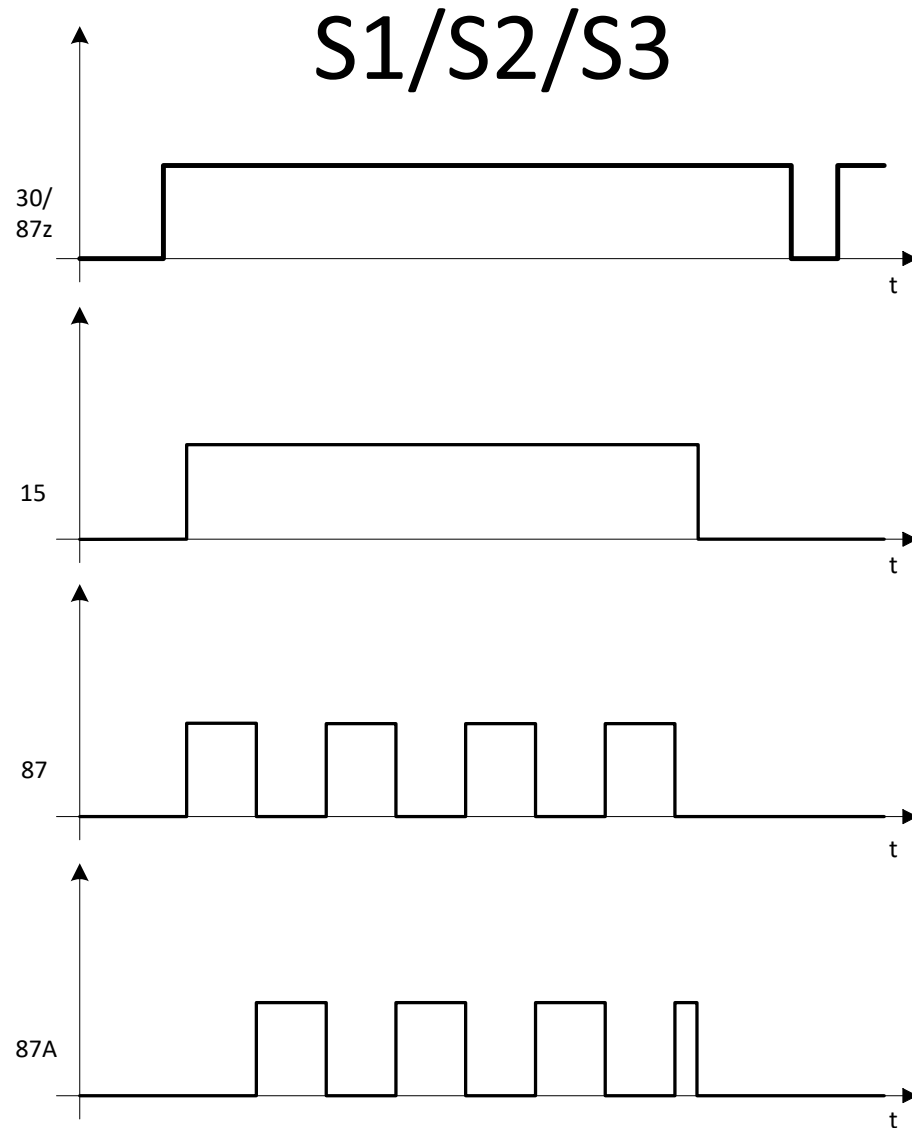

ACCESSORIES

Description	Order number
Programming tool MRS Realizer	1.100.100.01
Parameterization station MRS	1.100.000.02
Socket package watertight 40 mm	1.017.010.40
Socket	1.017.002.00
FASTON terminal for latching 6.3 mm 1.5-2.5 mm ²	103064
FASTON terminal for latching 2.8 mm 0.5-1.0 mm ²	105292



MANUFACTURER

MRS Electronic GmbH & Co. KG
Klaus-Gutsch-Str. 7
78628 Rottweil
Germany

NOTES ON WIRING AND CABLE ROUTING

The module must be protected against overcurrent with a suitable fuse.

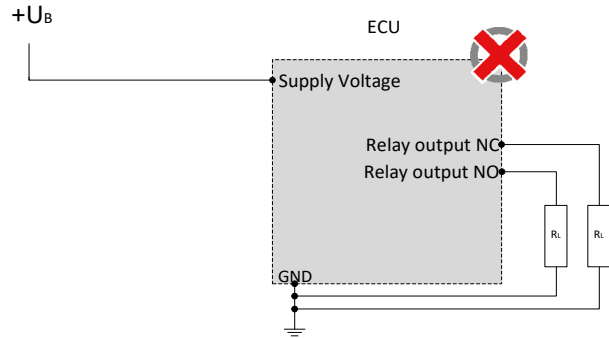
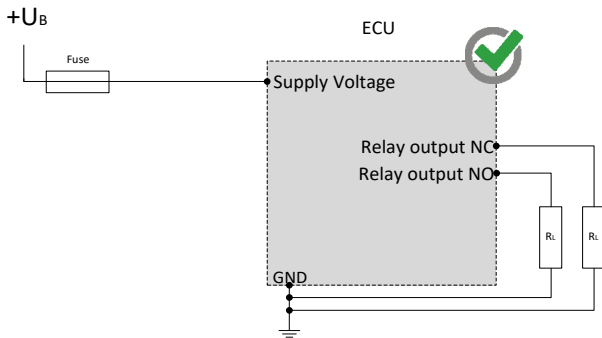

High-side driver outputs may only be connected to ground (S1).

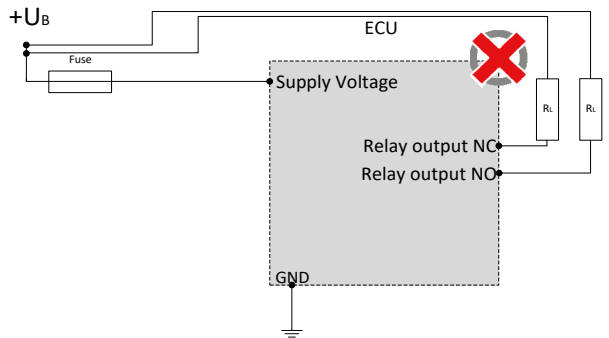
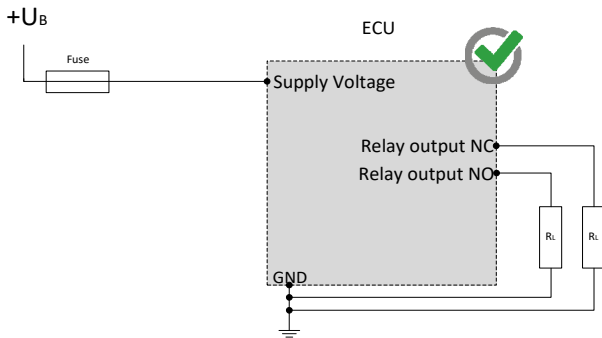

The potential-free relay connection must be fused separately (S2, S3).

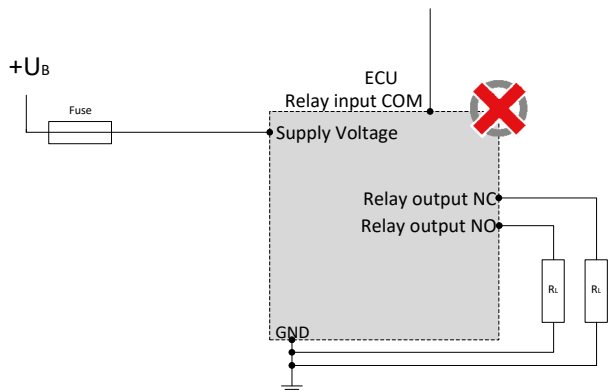
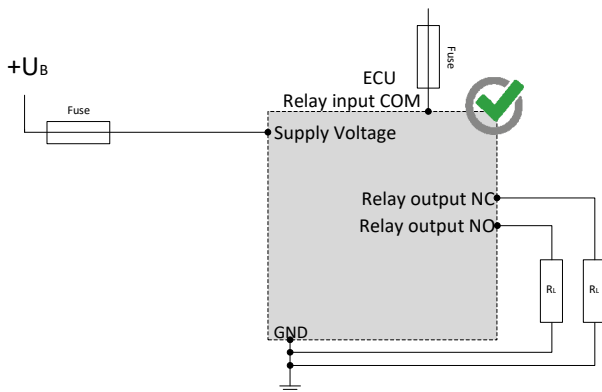

SAFETY AND INSTALLATION INFORMATION

It is essential to read the instructions in full thoroughly before working with the device.

Please note and comply with the instructions in the operating instructions and the information in the device data sheet, see www.mrs-electronic.com

Staff qualification: Only staff with the appropriate qualifications may work on this device or in its proximity.

SAFETY



WARNING! Danger as a result of a malfunction of the entire system.

Unforeseen reactions or malfunctions of the entire system may jeopardise the safety of people or the machine.

- Ensure that the device is equipped with the correct software and that the wiring and settings on the hardware are appropriate.



WARNING! Danger as a result of unprotected moving components.

Unforeseen dangers may occur from the entire system when putting the device into operation and maintaining it.

- Switch the entire system off before carrying out any work and prevent it from unintentionally switching back on.
- Before putting the device into operation, ensure that the entire system and parts of the system are safe.
- The device should never be connected or separated under load or voltage.



CAUTION! Risk of burns from the housing.

The temperature of the device housing may be elevated.

- Do not touch the housing and let all system components cool before working on the system.

PROPER USE

The device is used to control or switch one or more electrical systems or sub-systems in motor vehicles and machines and may only be used for this purpose. The device may only be used in an industrial setting.



WARNING! Danger caused by incorrect use.

The device is only intended for use in motor vehicles and machines.

- Use in safety-related system parts for personal protection is not permitted.
- Do not use the device in areas where there is a risk of explosion.

Correct use:

- operating the device within the operating areas specified and approved in the associated data sheet.
- strict compliance with these instructions and no other actions which may jeopardise the safety of individuals or the functionality of the device.

Obligations of the manufacturer of entire systems

It is necessary to ensure that only functional devices are used. If devices fail or malfunction, they must be replaced immediately.

System developments, installation and the putting into operation of electrical systems may only be carried out by trained and experienced staff who are sufficiently familiar with the handling of the components used and the entire system.

It is necessary to ensure that the wiring and programming of the device does not lead to safety-related malfunctions of the entire system in the event of a failure or a malfunction. System behaviour of this type can lead to a danger to life or high levels of material damage.

The manufacturer of the entire system is responsible for the correct connection of the entire periphery (e.g. cable cross sections, correct selection/connection of sensors/actuators).

Opening the device, making changes to the device and carrying out repairs are all prohibited. Changes or repairs made to the cabling can lead to dangerous malfunctions. Repairs may only be carried out by MRS.

Installation

The installation location must be selected so the device is exposed to as low a mechanical and thermal load as possible. The device may not be exposed to any chemical loads.

Install the device in such a manner that the plugs point downwards. This means condensation can flow off the device. Single seals on the cables/leads must be used to ensure that no water gets into the device.

Putting into operation

The device may only be put into operation by qualified staff. This may only occur when the status of the entire system corresponds to the applicable guidelines and regulations.

FAULT CORRECTION AND MAINTENANCE



NOTE The device is maintenance-free and may not be opened.

- If the device has damage to the housing, latches, seals or flat plugs, it must be taken out of operation.

Fault correction and cleaning work may only be carried out with the power turned off. Remove the device to correct faults and to clean it.

Check the integrity of the housing and all flat plugs, connections and pins for mechanical damage, damage caused by overheating, insulation damage and corrosion. In the event of faulty switching, check the software, switches and settings.

Do not clean the device with high pressure cleaners or steam jets. Do not use aggressive solvents or abrasive substances.