

DESCRIPTION

The CAN I/O & CAN PLC Waterproof module is a compact controller for automotive applications. Its high IP 68 protection rating (permanently waterproof and dustproof) in combination with user programmable graphical software make it the ideal solution for a wide range of automotive applications.

TECHNICAL DATA

Housing	Moulded plastic, sealed
Connector	Delphi / Aptiv - 211PC249S0033
Housing dimensions	60 x 60 x 30 mm (housing only) 95 x 77.3 x 33.5 mm (incl. tabs and connector)
Weight	170 g
Temperature range acc. to ISO 16750-4	-40 °C...+85 °C (at +85 °C rated power, see p. 5)
Environmental protection acc. to ISO 20653	IP68 when using the protection cap and corrugated tube acc. to the accessories list CAUTION! Follow the mechanical instructions!
Over-current Protection	20 A
Total Inputs and outputs	14 (6 inputs, 8 I/O's)
Inputs	Configurable as: Digital, positive encoder signal analog (0...11.4 / 33.68 V) Depending on assembly: Digital, low side switch encoder signal frequency input analog input (0...24.5 mA, PT1000 sensor)
Outputs	Configurable as: Digital, positive switching (high side) Depending on assembly: PWM output (3 Hz...500 Hz) reference voltage source (5 V/8 V)
Supply voltage	9...32 V 12 V (Code C) and 24 V (Code E), acc. to ISO 16750-2
Overvoltage protection	≥ 33 V
Current consumption	30 mA
Quiescent current	97 µA (at 24 V); 8.5 µA (at 12 V); at assembly variants with reference output higher ca. 4.7 mA

TECHNICAL DATA (CONTINUED)

Reverse polarity protection	yes
CAN interfaces	CAN bus interface 2.0 A/B, ISO 11898-2 compliant

REGULATORY APPROVALS AND TESTING

CE conformity	compliant
E1 label	UN/ECE-R10 radiated immunity with 100 V/m conducted immunity with 100 mA(BCI)
E1 approval	10 R - 06 7181
Electrical tests	According to ISO 16750-2 or -4: Short circuit protection (Exception: RS232 interface) Pin/connector Interruption Overvoltage at +65 °C Operation/storage test at +85 °C Superimposed alternating voltage Slow decrease and increase of supply voltage Momentary drop in supply voltage Reset behavior at voltage drop According to ISO 7637-2: Pulse 1, 2a, 2b, 3a, 3b Load dump test CNH-82036374-K-MP-180-E; (par. 13.7.10.3) 12V, R ₁ 4Ω, U _s 58V

SOFTWARE/PROGRAMMING

Programming System	MRS APPLICS STUDIO The Applis Studio is the new development and tool platform for our assemblies. Program your MRS controls quickly and easily with our stand-alone software. The focus is on your application.
--------------------	---

INPUT FEATURES - SUMMARY

Pin C3, C4, C5, C6, C7	Usable as analog or digital input Resolution Accuracy	12 Bit $\pm 1\%$ full scale	Pin A1, A2, A3, A4, A5, A6	Usable as analog or digital input Resolution Accuracy	12 Bit $\pm 1\%$ full scale
Voltage input 0...11.4 V (see A)	Input resistance Input frequency Accuracy	22.7 k Ω $f_g^1 = 60$ Hz $\pm 3\%$ max.	Voltage input 0...11.4 V (see E)	Input resistance Input frequency Accuracy	16 k Ω $f_g^1 = 60$ Hz $\pm 5\%$
Current input 0...24,5 mA (see C)	Input resistance Input frequency Conversion factor	500 Ω 40 Hz 1mA \approx 462 Digits	Digital input positive (see E)	Input resistance Input frequency Turn-on threshold Turn-off threshold	16 k Ω $f_g^1 = 60$ Hz 6.5 V 5 V
Frequency input (see D)	Input resistance Input frequency Turn-on threshold Turn-off threshold	22.7 k Ω $\pm 3\%$ accuracy at ≤ 2.2 kHz 6.5 V 5 V	Pin A7, A8	Usable as analog or digital input Resolution Accuracy	12 Bit $\pm 1\%$ full scale
Digital input positive (see A)	Input resistance Input frequency Turn-on threshold Turn-off threshold	22,7 k Ω $f_g^1 = 60$ Hz 7 V 4.5 V	Digital input positive (see E)	Input resistance Input frequency Turn-on threshold Turn-off threshold	22.7 k Ω $f_g^1 = 60$ Hz 6.5 V 5 V
Pin C2	Usable as analog or digital input Resolution Accuracy	12 Bit $\pm 1\%$ full scale			
Voltage input 0...33,68 V (see B)	Input resistance Input frequency Accuracy	66.6 k Ω $f_g^1 = 40$ Hz $\pm 3\%$			
Current input 0...24,5 mA (see C)	Input resistance Input frequency Conversion factor	470 Ω 40 Hz 1mA \approx 462 Digits			
Frequency input (see D)	Input resistance Input frequency Turn-on threshold Turn-off threshold	22.7 k Ω $\pm 3\%$ accuracy at ≤ 2.2 kHz 7 V 4.5 V			
Digital input positive (see B)	Input resistance Input frequency Turn-on threshold Turn-off threshold	66.6 k Ω $f_g^1 = 40$ Hz 19 V 14.3 V			

¹ cutoff frequency (-3 dB)

OUTPUT FEATURES - SUMMARY

Pin A1, A2	Protective circuit for inductive loads	Optionally integrated	Pin A3, A4, A5, A6, A7, A8	Protective circuit for inductive loads	Optionally integrated
	Wire fault diagnostics	Possible via current sense		Wire fault diagnostics	Possible via current sense
	Short circuit diagnostics	Possible via current sense		Short circuit diagnostics	Possible via current sense
Digital, positive switching (high side; see E)	Switching voltage Switching current Conversion factor current sense	9...32 V DC 0.02-2.5 A 1 Digit ≈ 2.3 mA	Digital, positive switching (high side; see E)	Switching voltage Switching current Conversion factor current sense	9...32 V DC 0.02-2.5 A 1 Digit ≈ 2.3 mA
Short circuit protection against GND and U _B	Internal overtemperature protection, latch-off can be realized by software application		PWM-output (see E)	Output frequency Duty cycle Resolution Switching current	500 Hz 0...1000 ‰ 1 ‰ ≥ 2.5 A (see below)
			Short circuit protection against GND and U _B	Internal overtemperature protection, latch-off can be realized by software application	

PERFORMANCE TESTS HIGH SIDE DRIVER VNQ5050AK

Test without PWM				Test with PWM			
	Test No.	Load	Endurance		Test No.	Load	Endurance
Endurance tests at +85 °C for digital outputs (max. 2 channels per high side driver)	1	4 x 2.5 A	Continuous	Endurance tests at +85 °C for PWM outputs with frequency=200 Hz and 90 % duty cycle (max. 2 channels per high side driver)	1	4 x 2.0 A	Continuous
	2	3 x 2.5 A 1 x 3.5 A	30 minutes		2	4 x 2.5 A	10 minutes
	3	2 x 2.5 A 2 x 3.5 A	15 minutes		3	1 x 3.5 A 3 x 2.5 A	2 minutes
	4	1 x 2.5 A 3 x 3.5 A	10 minutes		4	2 x 3.5 A	2 minutes
	5	2 x 5 A	5 minutes				

PIN ASSIGNMENT POWER SUPPLY AND INTERFACES

Pin	Description	Pin	Description
B1	Supply voltage for output pins A1 through A4, supply voltage for CPU	B6	Ground / contact 31
B2	CAN1-H	B7	VREF (assembly option see page 7, otherwise not connected)
B3	CAN1-L	B8	Supply voltage for output pins A5 through A8, supply voltage for CPU
B4	RS 485-A / RS 232 Tx (optional, see page 7)	C1	Ground / contact 31
B5	RS 485-B / RS 232 Rx (optional, see page 7)	C8	Battery / ignition contact 15 (optional as DI; see page 7) Supply pull-up inputs

PIN ASSIGNMENT INPUTS AND OUTPUTS

Pin	Signal	Description	Pin	Signal	Description
A1	ANA_IO0 / D_IN0 OUT_HSD0	Analog/digital input IO0 0-11.4 V or digital output DO0	A8	D_IN7 OUT_HSD7	Digital input IO7; 0-11.4 V or digital output DO7 with PWM capability
A2	ANA_IO1 / D_IN1 OUT_HSD1	Analog/digital input IO1; 0-11.4 V or digital output DO1	C2	ANA5/ D_ANA5	Analog input 5; 0-33.68 V can also be used as digital input
A3	ANA_IO2 / D_IN2 OUT_HSD2	Analog/digital input IO2; 0-11.4 V or digital output DO2 with PWM capability	C3	ANA4/ D_ANA4	Analog input 4; 0-11.4 V can also be used as digital input
A4	ANA_IO3 / D_IN3 OUT_HSD3	Analog/digital input IO3; 0-11.4 V or digital output DO3 with PWM capability	C4	ANA3/ D_ANA3	Analog input 3; 0-11.4 V can also be used as digital input
A5	ANA_IO4 / D_IN4 OUT_HSD4	Analog/digital input IO4; 0-11.4 V or digital output DO4 with PWM capability	C5	ANA2/ D_ANA2	Analog input 2; 0-11.4 V can also be used as digital input
A6	ANA_IO5 / D_IN5 OUT_HSD5	Analog/digital input IO5; 0-11.4 V or digital output DO5 with PWM capability	C6	ANA1/ D_ANA1	Analog input 1; 0-11.4 V can also be used as digital input
A7	D_IN6 OUT_HSD6	Digital input IO6; 0-11.4 V or digital output DO6 with PWM capability	C7	ANA0/ D_ANA0	Analog input 0; 0-11.4 V can also be used as digital input

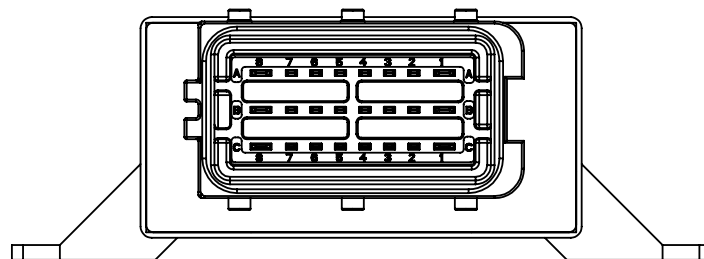

PIN FEATURE MAP

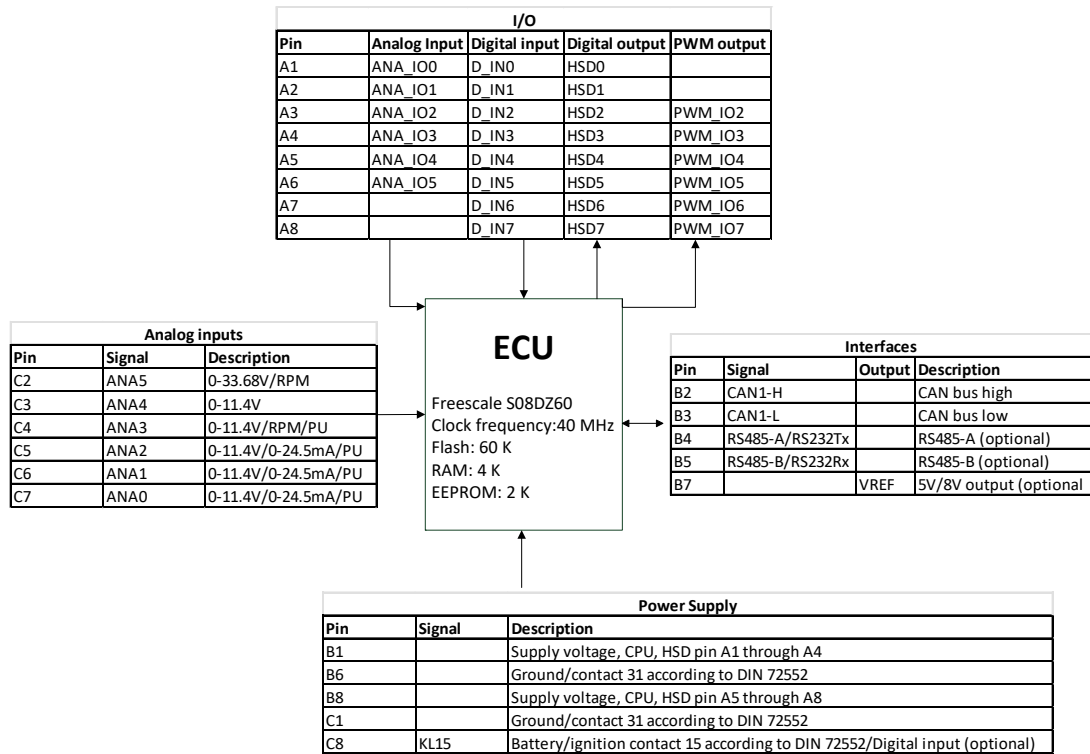

BLOCK FUNCTION DIAGRAM

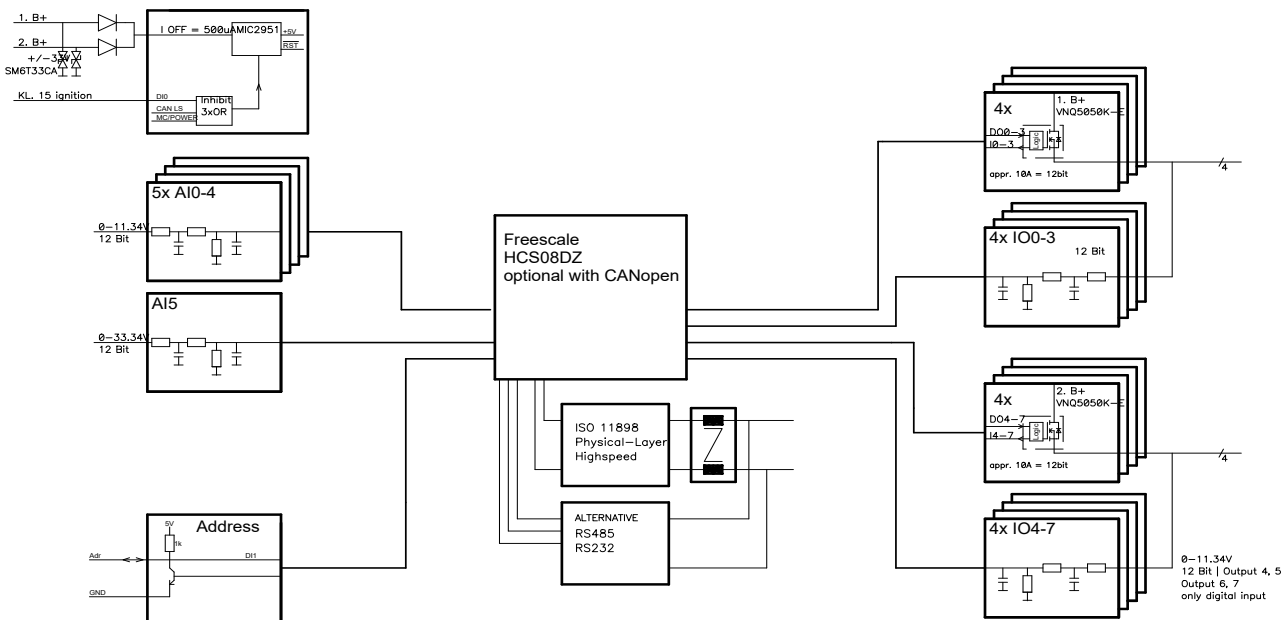

BLOCK FUNCTION DIAGRAM FOR ASSEMBLY OPTIONS



TECHNICAL DRAWING IN MM, TOLERANCES ACCORDING TO ISO 2768-1 V

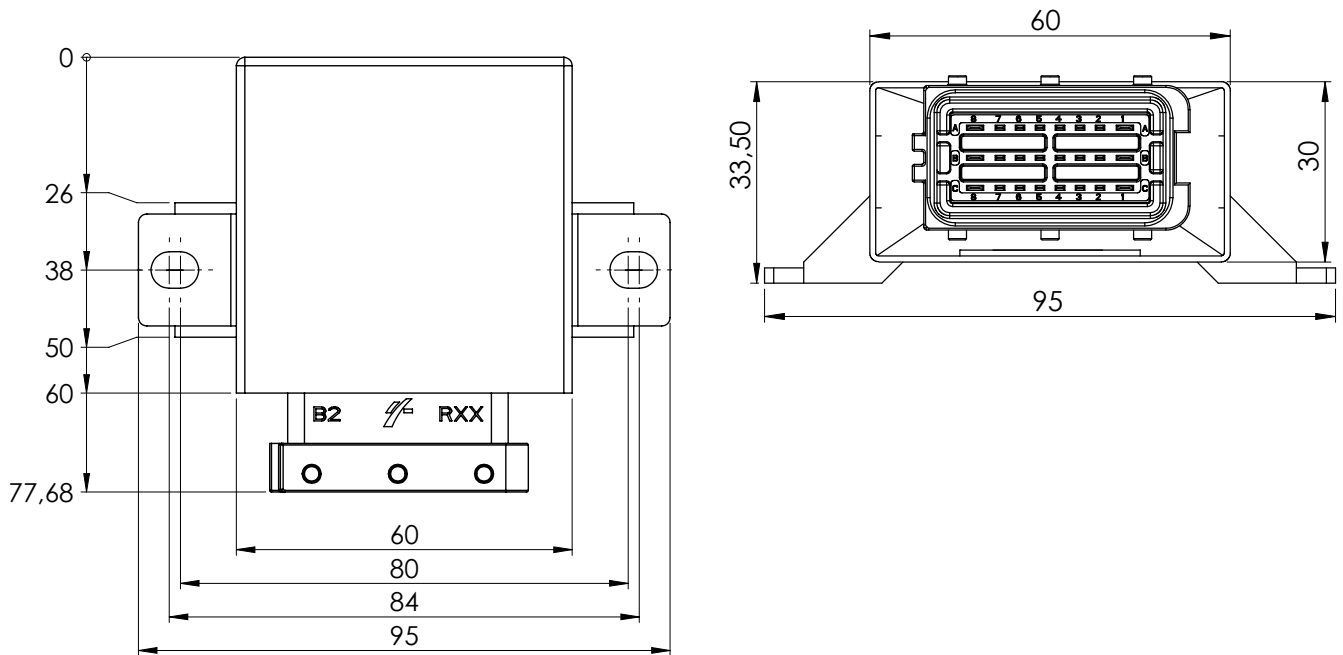

ASSEMBLY OPTIONS AND ORDER INFORMATION

	Inputs					Outputs		CAN Bus High Speed	Serial Interface	DC/DC	Processor
	A Voltage 0 – 11.4 V	B Voltage 0 – 33 V	C Current 0 - 24 mA	D Frequency Hz	Sensor inputs 10 kΩ Pull-up	E I/O's (can be used as analog or digital inputs or as digital outputs)	F PWM ≤ 500 Hz				
1.053.300.0000	C3,C4,C5,C6,C7	C2				A1,A2,A3,A4,A5,A6,A7,A8	A3,A4,A5,A6,A7,A8			5 Volt Referenz 8 Volt Referenz	DZ60
1.053.302.0000	C3,C5,C6,C7			C2,C4		A1,A2,A3,A4,A5,A6,A7,A8	A3,A4,A5,A6,A7,A8			B7 (5 V)	DZ60
1.053.302.1200	C3,C5,C6,C7			C2,C4		A1,A2,A3,A4,A5,A6,A7,A8	A3,A4,A5,A6,A7,A8			B7 (5 V)	DZ60
1.053.302.1300	C3,C5,C6,C7			C2,C4		A1,A2,A3,A4,A5,A6,A7,A8	A3,A4,A5,A6,A7,A8			B7 (5 V)	DZ128
1.053.303.0000	C3,C4	C2	C5,C6,C7			A1,A2,A3,A4,A5,A6,A7,A8	A3,A4,A5,A6,A7,A8				DZ60
1.053.304.1200	C3,C5,C6,C7			C2,C4	C2,C4	A1,A2,A3,A4,A5,A6,A7,A8	A3,A4,A5,A6,A7,A8			B7 (5 V)	DZ60
1.053.305.0000	C3,C5,C6,C7			C2,C4		A1,A2,A3,A4,A5,A6,A7,A8	A3,A4,A5,A6,A7,A8			B7 (8 V)	DZ60
1.053.306.0000	C3,C4	C2			C5,C6,C7	A1,A2,A3,A4,A5,A6,A7,A8	A3,A4,A5,A6,A7,A8				DZ60
1.053.307.0000	C3	C2			C4,C5,C6,C7	A1,A2,A3,A4,A5,A6,A7,A8	A3,A4,A5,A6,A7,A8				DZ60
1.053.307.0001	C3	C2			C4,C5,C6,C7	A1,A2,A3,A4,A5,A6,A7,A8	A3,A4,A5,A6,A7,A8				DZ128
1.053.310.0000	C3,C4,C5,C6,C7	C2				A1,A2,A3,A4,A5,A6,A7,A8	A3,A4,A5,A6,A7,A8		B4/B5 (RS485)		DZ60
1.053.320.1000	C3,C4,C5,C6,C7	C2				A1,A2,A3,A4,A5,A6,A7,A8	A3,A4,A5,A6,A7,A8		B4/B5 (RS232)		DZ128
1.053P.300.0000	C3,C4,C5,C6,C7	C2				A1,A2,A3,A4,A5,A6,A7,A8	A3,A4,A5,A6,A7,A8	CANopen			DZ60
1.053P.305.0000	C3,C5,C6,C7			C2,C4		A1,A2,A3,A4,A5,A6,A7,A8	A3,A4,A5,A6,A7,A8	CANopen		B7 (8 V)	DZ60

Order number with the last 4 digits 1000 or 1200 indicate that the device is active after the supply voltage is connected to pins B1 and B8 (supply voltage contact 30); pin C8 (ignition contact 15) can be used as digital input in this case.

SCIP NUMBERS

Assembly Variant	SCIP Number
1.053.300.0000	191e3cbe-8eb4-4123-9c56-80ad440b4614
1.053.302.xxxx	de4afde0-03d2-42b8-b328-949fb6d5103c
1.053.303.0000	185540ec-f821-43c1-aed0-c5b772aaef56
1.053.304.1200	68d07294-e8fb-4269-9307-5561b03f0a66
1.053.305.0000	de4afde0-03d2-42b8-b328-949fb6d5103c
1.053.306.0000	191e3cbe-8eb4-4123-9c56-80ad440b4614
1.053.307.xxxx	185540ec-f821-43c1-aed0-c5b772aaef56
1.053.310.0000	185540ec-f821-43c1-aed0-c5b772aaef56
1.053.320.1000	191e3cbe-8eb4-4123-9c56-80ad440b4614
1.053P.300.0000	191e3cbe-8eb4-4123-9c56-80ad440b4614
1.053P.305.0000	de4afde0-03d2-42b8-b328-949fb6d5103c

ACCESSORIES

Description	Order number
Programming tool MRS Applies Studio	1.100.200.01
Cable set CAN I/O WP	112342
Connector package CAN I/O WP	110421
Protection cap	111441
Corrugated tube (outer diameter: 21.2 mm; inner diameter: 16.5 mm)	Available from independent retailers
Crimp contact 2.8 mm/1-2.5 mm ²	109947
Crimp contact 1.5 mm/1.3-2 mm ²	109949
Dummy FCI filler plug	110268
PCAN-USB Interface	105358



MANUFACTURER

MRS Electronic GmbH & Co. KG
 Klaus-Gutsch-Str. 7
 78628 Rottweil

NOTES ON WIRING AND CABLE ROUTING

The electronic system and the power outputs of a control unit must be supplied by the same power supply system.

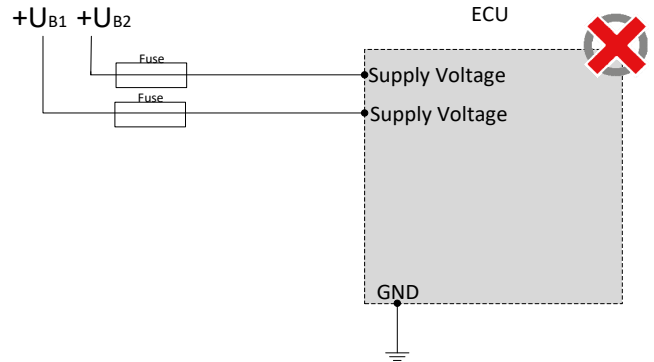
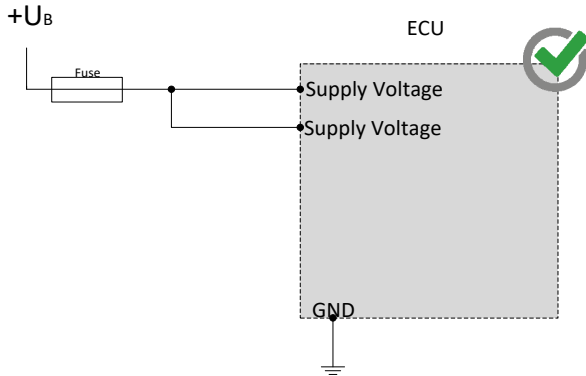

PWM outputs may not be connected with each other or bypassed.

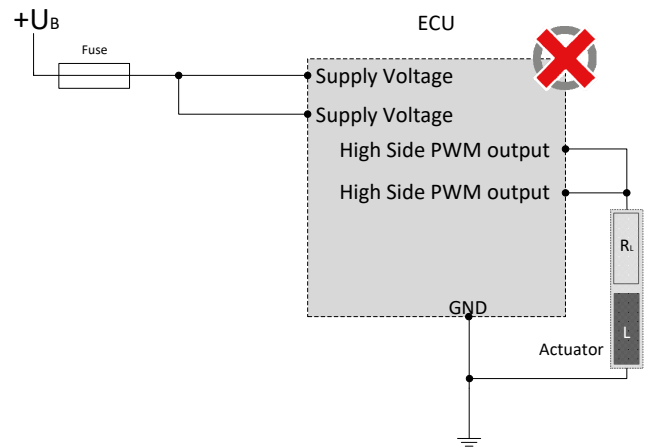
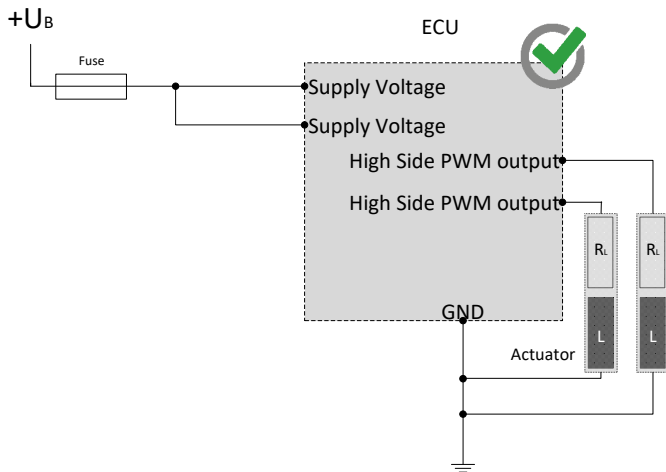

The pins (I/Os) can be used in combination and may not be switched externally against a higher voltage level than supply voltage.

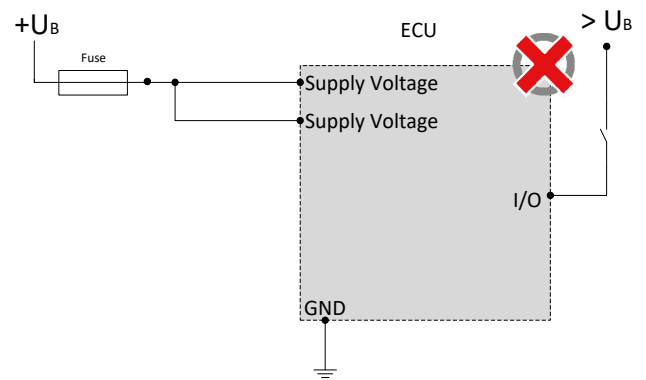
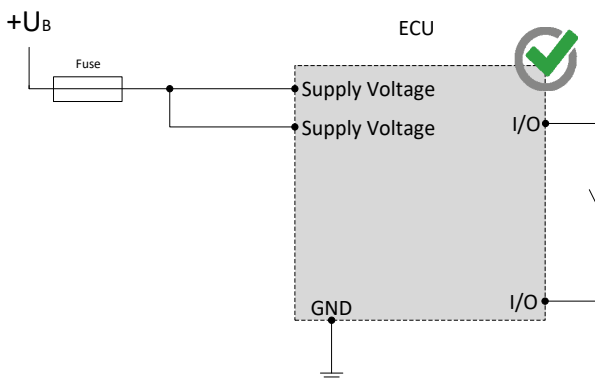

To comply with the IP protection class, the wiring harness attached to the mating connector must be routed through the corrugated tube and the mating connector must be connected to the control unit. The protection cap is then closed over the mating connector and the corrugated tube.

NOTES ON WIRING AND CABLE ROUTING

Hightside outputs may only be switched to ground.

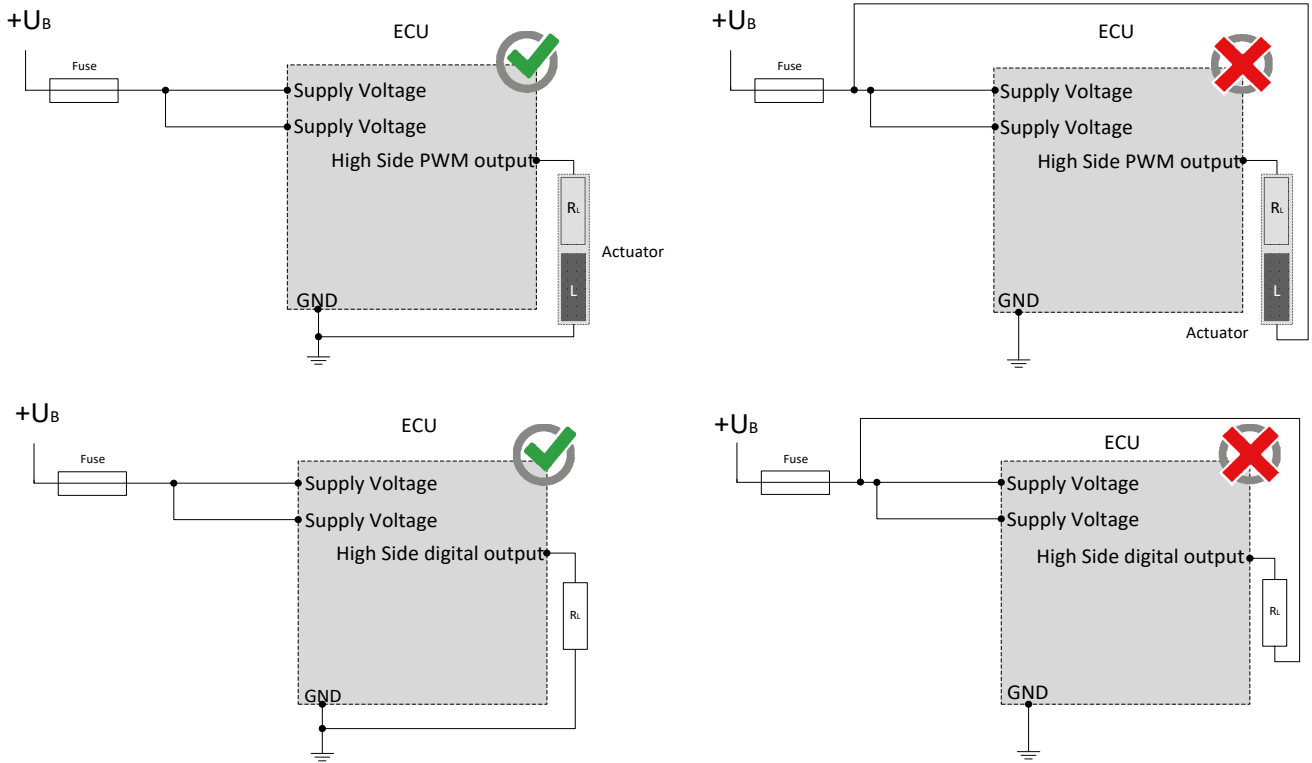

The sensor supplies can be “lifted” through an external circuitry, for example the creation of higher voltage, as they only work as a voltage source but not as voltage drain. The lift of a voltage source may lead to unforeseen malfunctions and damages of the control unit in case of permanent operation.

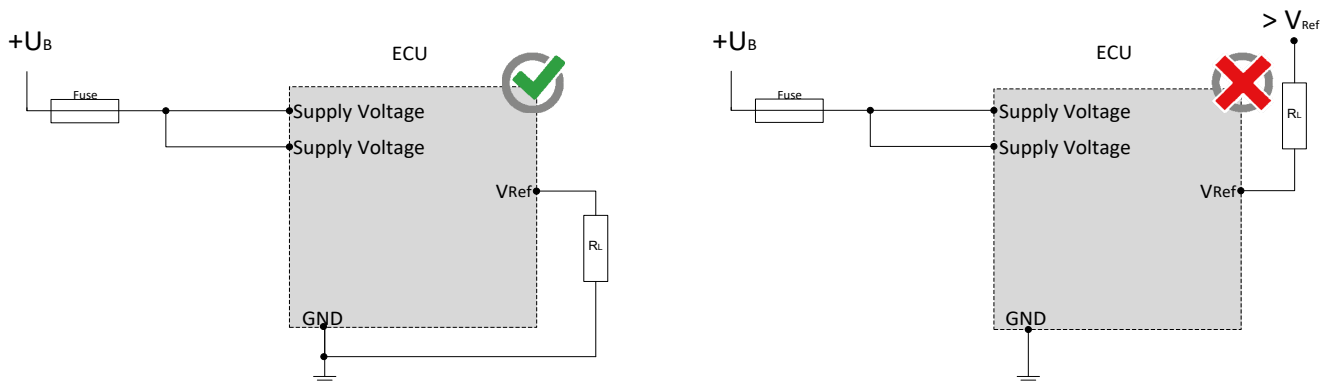

CAN bus communication is the main communication between the control unit and the vehicle. Therefore, connect the CAN bus with special care and check the correct communication with the vehicle to avoid undesired behavior.

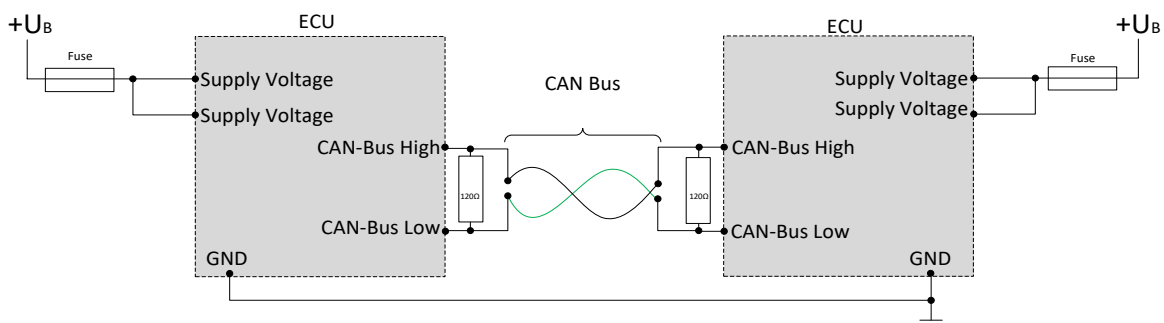

SAFETY AND INSTALLATION INFORMATION

It is essential to read the instructions in full thoroughly before working with the device.

Please note and comply with the instructions in the operating instructions and the information in the device data sheet, see www.mrs-electronic.de

Staff qualification: Only staff with the appropriate qualifications may work on this device or in its proximity.

SAFETY



WARNING! Danger as a result of a malfunction of the entire system.

Unforeseen reactions or malfunctions of the entire system may jeopardise the safety of people or the machine.

- Ensure that the device is equipped with the correct software and that the wiring and settings on the hardware are appropriate.



WARNING! Danger as a result of unprotected moving components.

Unforeseen dangers may occur from the entire system when putting the device into operation and maintaining it.

- Switch the entire system off before carrying out any work and prevent it from unintentionally switching back on.
- Before putting the device into operation, ensure that the entire system and parts of the system are safe.
- The device should never be connected or separated under load or voltage.



CAUTION! Risk of burns from the housing.

The temperature of the device housing may be elevated.

- Do not touch the housing and let all system components cool before working on the system.

PROPER USE

The device is used to control or switch one or more electrical systems or sub-systems in motor vehicles and machines and may only be used for this purpose. The device may only be used in an industrial setting.



WARNING! Danger caused by incorrect use.

The device is only intended for use in motor vehicles and machines.

- Use in safety-related system parts for personal protection is not permitted.
- Do not use the device in areas where there is a risk of explosion.

Correct use:

- operating the device within the operating areas specified and approved in the associated data sheet.
- strict compliance with these instructions and no other actions which may jeopardise the safety of individuals or the functionality of the device.

Obligations of the manufacturer of entire systems

It is necessary to ensure that only functional devices are used. If devices fail or malfunction, they must be replaced immediately.

System developments, installation and the putting into operation of electrical systems may only be carried out by trained and experienced staff who are sufficiently familiar with the handling of the components used and the entire system.

It is necessary to ensure that the wiring and programming of the device does not lead to safety-related malfunctions of the entire system in the event of a failure or a malfunction. System behaviour of this type can lead to a danger to life or high levels of material damage.

The manufacturer of the entire system is responsible for the correct connection of the entire periphery (e.g. cable cross sections, correct selection/connection of sensors/actuators).

Opening the device, making changes to the device and carrying out repairs are all prohibited. Changes or repairs made to the cabling can lead to dangerous malfunctions. Repairs may only be carried out by MRS.

Installation

The installation location must be selected so the device is exposed to as low a mechanical and thermal load as possible. The device may not be exposed to any chemical loads.

Install the device in such a manner that the plugs point downwards. This means condensation can flow off the device. Single seals on the cables/leads must be used to ensure that no water gets into the device.

Putting into operation

The device may only be put into operation by qualified staff. This may only occur when the status of the entire system corresponds to the applicable guidelines and regulations.

FAULT CORRECTION AND MAINTENANCE



NOTE The device is maintenance-free and may not be opened.

- If the device has damage to the housing, latches, seals or flat plugs, it must be taken out of operation.

Fault correction and cleaning work may only be carried out with the power turned off. Remove the device to correct faults and to clean it.

Check the integrity of the housing and all flat plugs, connections and pins for mechanical damage, damage caused by overheating, insulation damage and corrosion. In the event of faulty switching, check the software, switches and settings.

Do not clean the device with high pressure cleaners or steam jets. Do not use aggressive solvents or abrasive substances.