

mounting direction

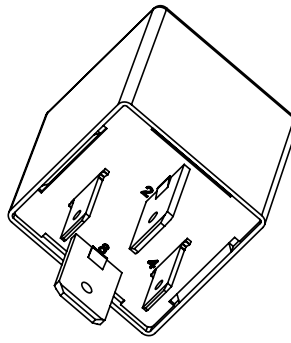

view of plug

## DESCRIPTION

The High Current Time Relay Compact – Switch On-/Off Delay 9-30V/70A is a small, powerful and cost-effective controller, which is characterized by even higher performance compared to the M1 controller (M1HC).

## TECHNICAL DATA

Housing	Plastic PA 66GF30
Connector	Base plate 4-pin
Weight	33 g
Temperature range (ISO 16750-4 compliant)	-40 °C to +85 °C
Environmental Protection	IP 53
Current consumption	0.9 mA
Over-current protection	1A + load
Total Inputs and outputs	1 switching input / 1 relay output (2)
Inputs	Digital, positive encoder signals
Outputs	1 relay output
Operating voltage	6.5-32 V acc. to ISO 16750-2: 12 V (Code B) 24 V (Code E)
Overvoltage protection	Above ~ 36.5 V active pulse reduction
Quiescent current	NA
Reverse polarity protection	Yes
CAN interfaces	No

## SOFTWARE/PROGRAMMING

### Programming system

The programming tool MRS Realizer is the suitable software for the simple and fast programming of the MRS controllers. The parameterization takes place uncomplicatedly via the relay contacts, saving you valuable time for opening the time for opening the housing. Easily create own programs for your application via the Z-Graph.

For this purpose, graphical function blocks (based on IEC61131) are available in EAGLETM. You can download the new AUTODESK® EAGLETM version according to your needs and requirements on the AUTODESK® EAGLETM homepage.

## REGULATORY APPROVALS AND TESTING

E1 approval	ECE R10 06 9521
Electrical tests	<p><b>Acc. to ISO 16750 – 2 resp. -4:</b> Short circuit protection Reverse polarity Interruption pin and connector Long time overvoltage at TMax-20 °C Storage test at TMax and TMin Operation test at TMax and TMin Start pulse (former pulse 4 acc. to ISO 7637)</p> <p>Acc. to ISO 7637 - 2: Pulse 1, 2a, 2b, 3a, 3b, severity level III</p> <p><b>Acc. to ISO 10605</b> ESD ± 15 kV</p> <p><b>EMV Messung acc. to ECE R10:</b> Electricity input acc. to ISO 11452-4: 4. edition 2011 Measurement of broadband/narrowband electromagnetic interference radiation Acc. to CISPR 25 2. edition + correction 2004 Measurement of conducted interference emission acc. to ISO 7637-2, 2. edition 2004 Immunity to radiated electromagnetic fields acc. to ISO 11452-4, 4. edition 2011 resp. ISO 11452-2. 2. edition 2004 Interference immunity against conducted disturbances acc. to ISO 7637-2. 2. edition 2004</p>

Autodesk® is a registered trademark of Autodesk Inc, EagleTM is a registered trademark of Autodesk Inc.

## INPUT FEATURES - SUMMARY

<b>Pin 4 (KL15)</b>	Programmable as digital input	
Digital input positive (see <a href="#">A</a> )	Input resistance	10 kΩ
	Turn-on threshold	6.1 ± 0.2 V
	Turn-off threshold	3.6 ± 0.2 V

## OUTPUT FEATURES - SUMMARY

<b>Pin 8 (87, NO)</b>	Protective circuit for inductive loads	Not integrated	<b>Max. switching current [A]</b>	<b>Duration [min]</b>
			15	permanent
Digital, positive switching (Relay, see <a href="#">B</a> )	Switching voltage	6.5-32 V	20	12
	max. switch-on current <sup>1</sup>	70 A Make 60 A Brake	25	7
	max. permanent current <sup>2</sup>	35 A	30	5:30
	max. switching current	see table	35	4:30
	max. mechanical service life	1x10 <sup>7</sup> OPS	40	2
Short circuit resistance against GND	Protection by external fuse (see „notes on wiring and cable routing“)			
Over-current protection	Up to ~ 36.5 V, above active pulse reduction			

<sup>1</sup> max. peak switch-on current with electronic load for 3 min at 16 V, at +20 °C

<sup>2</sup> 30 min with resistive load, 16 V at +85 °C

<sup>3</sup> 30 s on / 30 s off with resistive load; 24 V at +85 °C

PIN ASSIGNMENT

Pin	Description	Pin	Description
2	Contact 30 /	6	Contact 31 / GND
4	Contact 15 / switching input	8	Contact 87 / Relay output NO

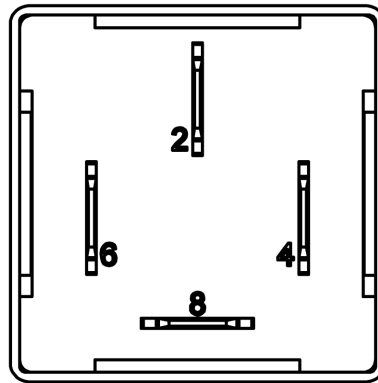

PIN FEATURE MAP

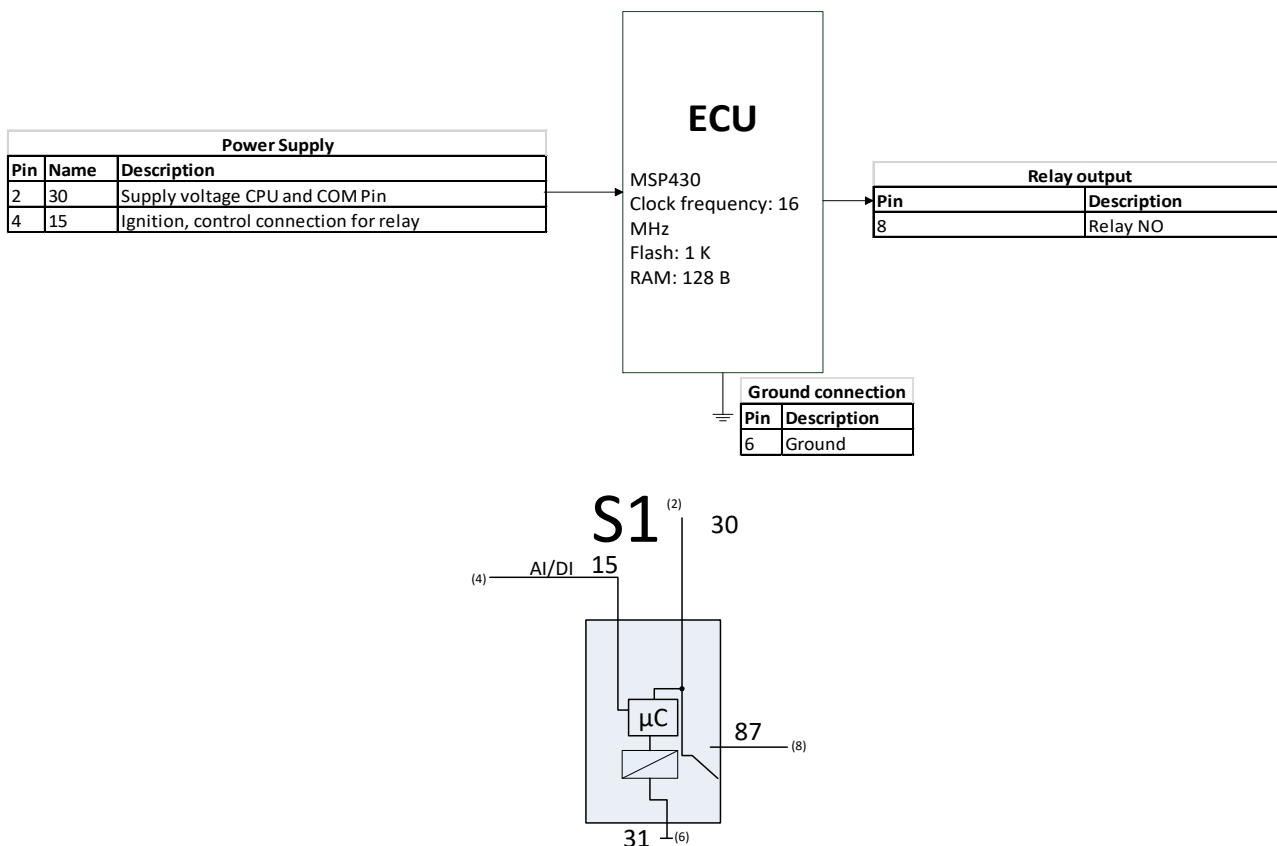

BLOCK FUNCTION DIAGRAM

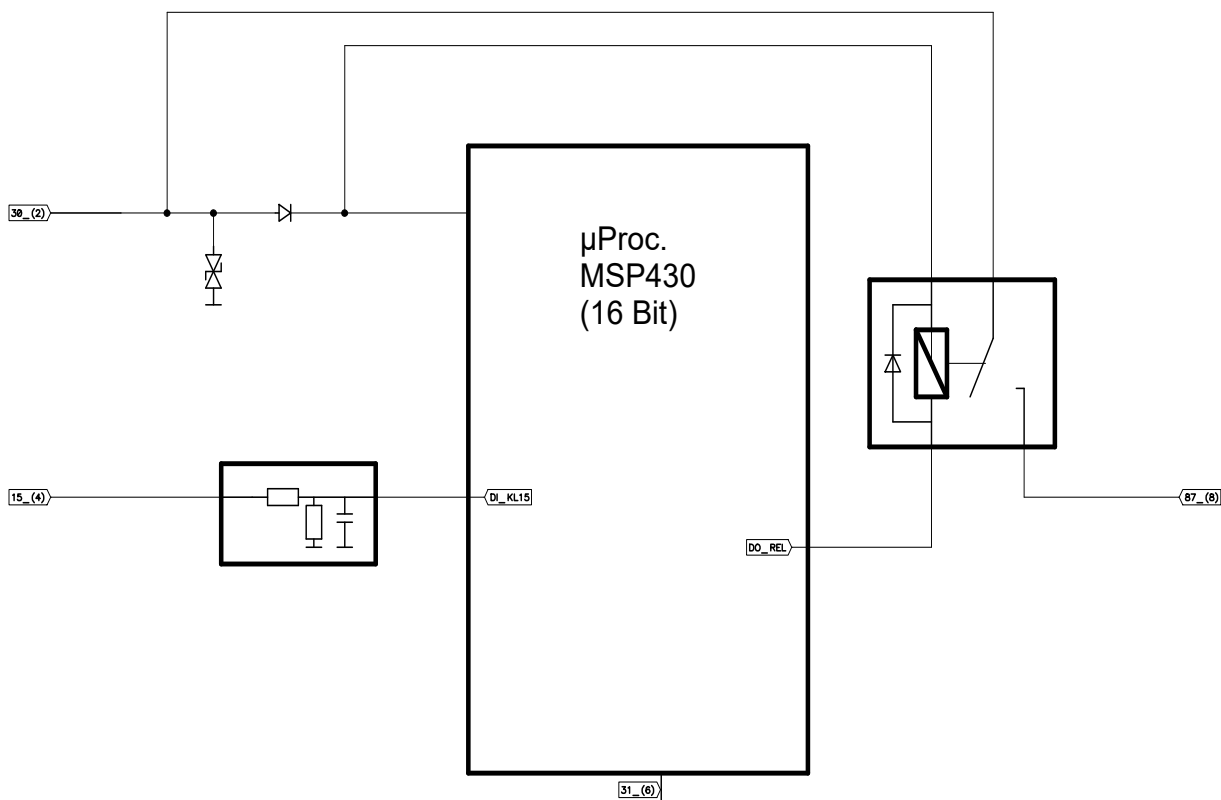

TECHNICAL DRAWING IN MM [INCH]

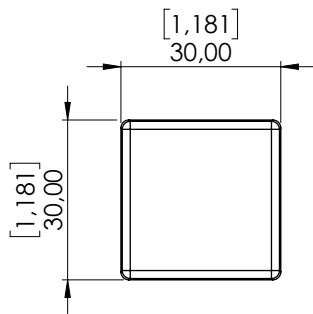

top view

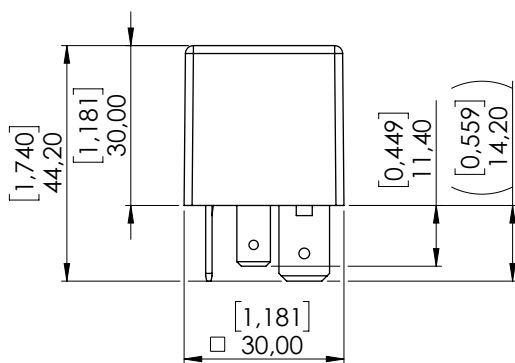

side view

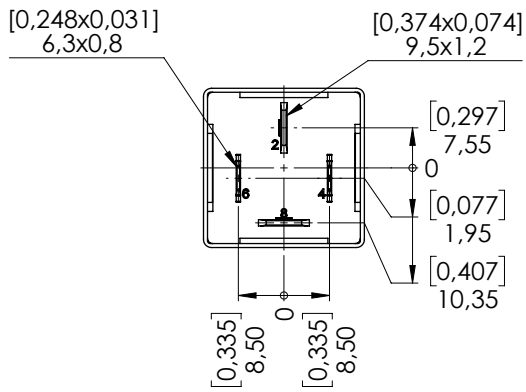

bottom view

ASSEMBLY OPTIONS AND ORDER INFORMATION TIME RELAY COMPACT 70A SWITCH OFF DELAY

	Inputs	Outputs	Remarks
	A Switching input digital	B Relay output NO	
<b>1.070.300.XXX</b>	4	8	Switch off delay; when ordering, please specify individual delay time

FUNCTION DIAGRAM TIME RELAY COMPACT 70A SWITCH OFF DELAY

If the voltage is set at terminal 15, the relay will pull immediately on. If the voltage is removed at terminal 15, the relay drops off at the end of the specified time.

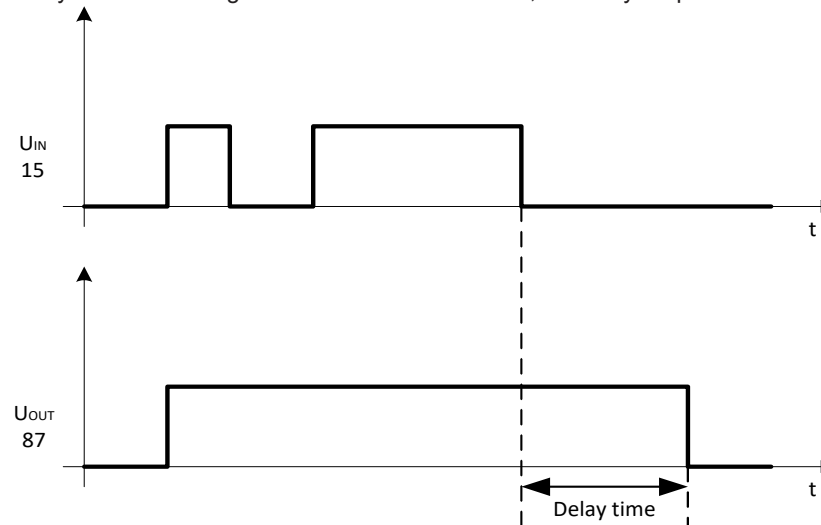

ASSEMBLY OPTIONS AND ORDER INFORMATION TIME RELAY COMPACT 70A SWITCH ON DELAY

	Inputs	Outputs	Remarks
	A Switching input digital	B Relay output NO	
1.070.301.XXX	4	8	Switch on delay; when ordering, please specify individual delay time

FUNCTION DIAGRAM TIME RELAY COMPACT 70A SWITCH ON DELAY

If the voltage is set at terminal 15, the relay will pull on at the end of the specified time. If the voltage is removed at terminal 15, the relay immediately drops off.

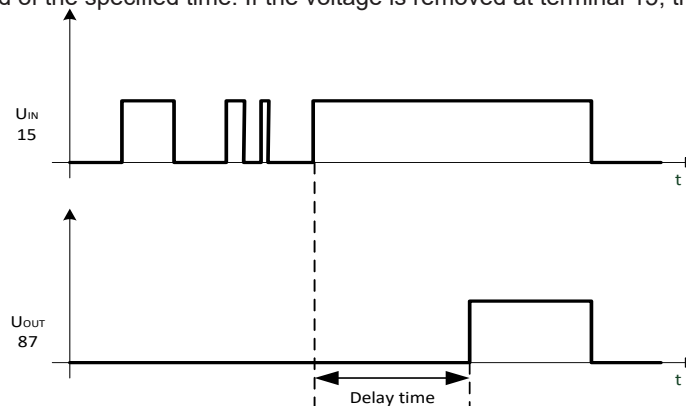

## ACCESSORIES

Description	Order number
Parameterization station MRS	1.100.000.02
Socket	1.017.001.00
FASTON terminal latch 6,3 mm/1,5-2,5 mm <sup>2</sup>	103064
FASTON terminal latch 9,5 mm/4,0-6,0 mm <sup>2</sup>	103066

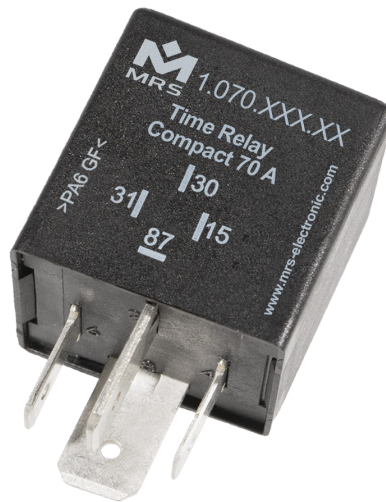

## MANUFACTURER

MRS Electronic GmbH & Co. KG  
Klaus-Gutsch-Str. 7  
78628 Rottweil  
Germany



NOTES ON WIRING AND CABLE ROUTING

The controller must be appropriately protected against overload (see performance data)

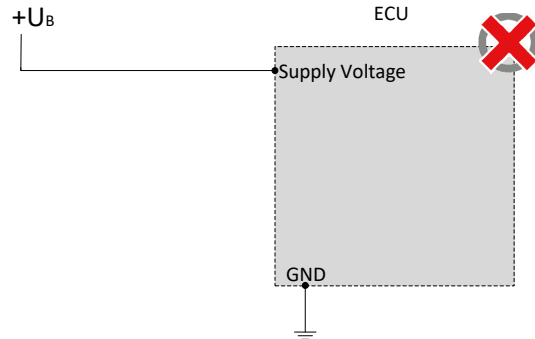
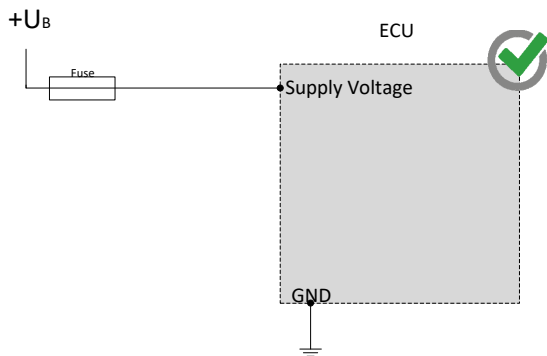

The relay may only be connected to ground.

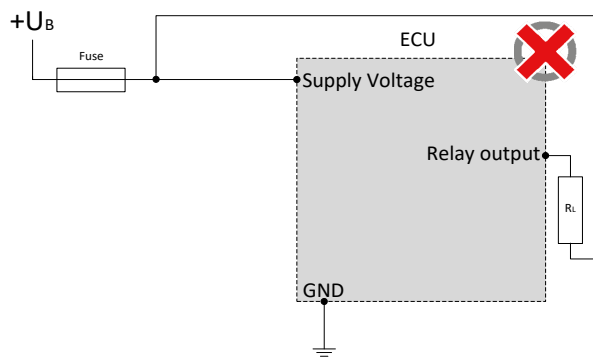
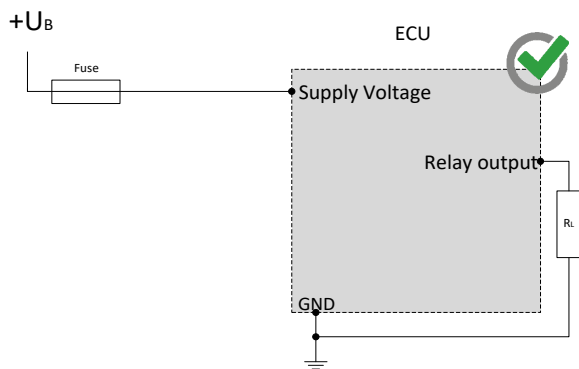

## SAFETY AND INSTALLATION INFORMATION

It is essential to read the instructions in full thoroughly before working with the device.

Please note and comply with the instructions in the operating instructions and the information in the device data sheet, see [www.mrs-electronic.com](http://www.mrs-electronic.com)

**Staff qualification:** Only staff with the appropriate qualifications may work on this device or in its proximity.

### SAFETY



**WARNING! Danger as a result of a malfunction of the entire system.**

Unforeseen reactions or malfunctions of the entire system may jeopardise the safety of people or the machine.

- Ensure that the device is equipped with the correct software and that the wiring and settings on the hardware are appropriate.



**WARNING! Danger as a result of unprotected moving components.**

Unforeseen dangers may occur from the entire system when putting the device into operation and maintaining it.

- Switch the entire system off before carrying out any work and prevent it from unintentionally switching back on.
- Before putting the device into operation, ensure that the entire system and parts of the system are safe.
- The device should never be connected or separated under load or voltage.



**CAUTION! Risk of burns from the housing.**

The temperature of the device housing may be elevated.

- Do not touch the housing and let all system components cool before working on the system.

### PROPER USE

The device is used to control or switch one or more electrical systems or sub-systems in motor vehicles and machines and may only be used for this purpose. The device may only be used in an industrial setting.



**WARNING! Danger caused by incorrect use.**

The device is only intended for use in motor vehicles and machines.

- Use in safety-related system parts for personal protection is not permitted.
- Do not use the device in areas where there is a risk of explosion.

**Correct use:**

- operating the device within the operating areas specified and approved in the associated data sheet.
- strict compliance with these instructions and no other actions which may jeopardise the safety of individuals or the functionality of the device.

**Obligations of the manufacturer of entire systems**

It is necessary to ensure that only functional devices are used. If devices fail or malfunction, they must be replaced immediately.

System developments, installation and the putting into operation of electrical systems may only be carried out by trained and experienced staff who are sufficiently familiar with the handling of the components used and the entire system.

It is necessary to ensure that the wiring and programming of the device does not lead to safety-related malfunctions of the entire system in the event of a failure or a malfunction. System behaviour of this type can lead to a danger to life or high levels of material damage.

The manufacturer of the entire system is responsible for the correct connection of the entire periphery (e.g. cable cross sections, correct selection/connection of sensors/actuators).

Opening the device, making changes to the device and carrying out repairs are all prohibited. Changes or repairs made to the cabling can lead to dangerous malfunctions. Repairs may only be carried out by MRS.

**Installation**

The installation location must be selected so the device is exposed to as low a mechanical and thermal load as possible. The device may not be exposed to any chemical loads.

Install the device in such a manner that the plugs point downwards. This means condensation can flow off the device. Single seals on the cables/leads must be used to ensure that no water gets into the device.

**Putting into operation**

The device may only be put into operation by qualified staff. This may only occur when the status of the entire system corresponds to the applicable guidelines and regulations.

### FAULT CORRECTION AND MAINTENANCE



**NOTE The device is maintenance-free and may not be opened.**

- If the device has damage to the housing, latches, seals or flat plugs, it must be taken out of operation.

Fault correction and cleaning work may only be carried out with the power turned off. Remove the device to correct faults and to clean it.

Check the integrity of the housing and all flat plugs, connections and pins for mechanical damage, damage caused by overheating, insulation damage and corrosion. In the event of faulty switching, check the software, switches and settings.

Do not clean the device with high pressure cleaners or steam jets. Do not use aggressive solvents or abrasive substances.