

mounting direction

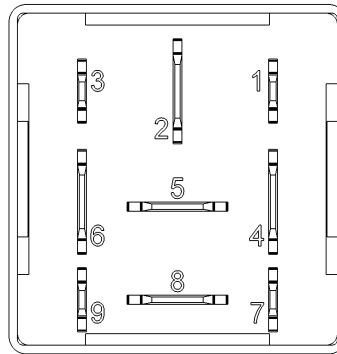

view of plug

DESCRIPTION

The most compact Gateway of MRS Electronic is the Micro PLC CAN LIN. This gateway has been developed and built on the basis of a micro PLC CAN. It has 9 pins with a CAN and LIN interface. The product can be delivered as LIN Slave or as LIN Master circuitry and is perfect for tight installation spaces.

TECHNICAL DATA

Housing	Plastic PA66GF30
Connector	9 pin base plate
Weight	30 g
Temperature range acc. to ISO 16750-4	-40 °C...+85 °C
Environmental protection acc. to ISO 20653	IP6K8, when using the waterproof socket and correct installation position (plug vertically downwards)
Current consumption	40 mA
Over-current protection	2 A
Total inputs and outputs	4 (2 analog & digital inputs, 2 I/Os)
Inputs	Configurable as: Analog input Digital input, positive encoder signal
Outputs	Configurable as: Digital, positive switching (high side) PWM output (≤ 30 kHz)
Supply voltage	8...16 V (Code B for 12 V, acc. to ISO 16750-2)
Overvoltage protection	≥ 33 V
Quiescent current	50 μ A
Reverse polarity protection	yes
CAN interface	CAN Interface 2.0 A/B, ISO11898-5
LIN interface	Lin Spec 2.0, 2.1

REGULATORY APPROVALS AND TESTING

E1 approval	10 R - 05 7069
Electrical tests	Acc. to ISO 16750-2 or -4: Short circuit protection Jump start Reverse polarity test Disruption pin and plug Long-term overvoltage at $T_{max} - 20$ °C Storage test at $T_{+85^{\circ}C}$ and $T_{-40^{\circ}C}$ Operation test at $T_{+85^{\circ}C}$ and $T_{-40^{\circ}C}$ Superimposed alternating voltage Slow decrease and increase of supply voltage Momentary drop in supply voltage Reset behavior at voltage drop Acc. to ISO 7637-2: Puls 1, 2a, 2b, 3a, 3b, 4 Acc. to ISO 10605: ESD handling test / powered up test up to ± 15 kV Radiation measurement within the scope of ECE R10 Rev. 05

SOFTWARE/PROGRAMMING

Programming System

MRS APPLICS STUDIO

The Applics Studio is the new development and tool platform for our assemblies. Program your MRS controls quickly and easily with our stand-alone software. The focus is on your application.

INPUT FEATURES - SUMMARY

Pin 1 (X)	Usable as analog or digital input Resolution Accuracy	12 Bit $\pm 1\%$ full scale	Pin 4 (15)	Usable as analog or digital input Resolution Accuracy	12 Bit $\pm 1\%$ full scale
Voltage input 0...14.3 V (see A)	Input resistance Input frequency Conversion factor Accuracy	28 k Ω $f_c^1 = 57 \pm 3$ Hz 1 mV \approx 3.5 digit $\pm 3\%$	Voltage input 0...11 V (see C)	Input resistance Input frequency Conversion factor Accuracy	20 k Ω $f_c^1 = 79 \pm 3$ Hz 1 mV \approx 2.7 digit $\pm 3\%$
Voltage input 0...14.3 V (see E)	Input resistance Input frequency Conversion factor Accuracy Pull-up	28 k Ω $f_c^1 = 57 \pm 3$ Hz 1 mV \approx 3.5 digit $\pm 3\%$ 20 k Ω against supply	Digital input positive (see B)	Input resistance Turn-on threshold Turn-off threshold	20 k Ω 5.8 ± 0.2 V 5.7 ± 0.2 V
Digital input positive (see B)	Turn-on threshold Turn-off threshold	5.8 ± 0.2 V 5.7 ± 0.2 V	Pin 5 (OUT2) PIN 8 (OUT1)	Usable as analog or digital input Resolution Accuracy	12 Bit $\pm 1\%$ full scale
Frequency input (see D)	Input resistance Turn-on threshold Accuracy	21 k Ω 8.3 V $100 \text{ Hz} \leq \pm 3\% \leq 3 \text{ kHz}^2$	Voltage input 0...33 V (see E)	Input resistance Input frequency Conversion factor Accuracy	33 k Ω $f_c^1 = 45 \pm 3$ Hz 1 mV \approx 8.06 digit $\pm 3\%$
			Digital input positive (see E)	Input resistance Turn-on threshold Turn-off threshold	33 k Ω 7.6 ± 0.2 V 7.4 ± 0.2 V

¹ cutoff frequency (-3 dB)² measured with square wave signal, 0...10V_{pp} 50 % DC

OUTPUT FEATURES - SUMMARY

Pin 5, 8 (OUT2, OUT1) TLE 4207	Protective circuit for inductive loads Wire fault diagnostics High side driver Overtemperature protection high side driver	not integrated Via Error Flag (DI_OUT_ERR=1) integrated	Functional Truth Table			
Digital, positive switching (high side; see E)	Switching voltage Max. switching current (permanently at +85 °C)	8...16 V 400 mA (Σ 800 mA)	DO_INH_OUT	DO_OUT1	DO_OUT2	Mode
PWM output (see E)	Output frequency Max. switching current (permanently at +85 °C)	≤ 30 kHz 400 mA (Σ 800 mA)	0	X	X	Output is in tristate
Short circuit resistance against GND and V _B	The individual outputs are switched off by output drivers		1	0	0	Brake sink condition
Output driver can optionally be set to standby mode via DO_INH_OUT=0			1	0	1	Clockwise
			1	1	0	Counter clockwise
			1	1	1	Brake source condition

PIN ASSIGNMENT POWER SUPPLY AND INTERFACES

Pin	Description	Pin	Description
2	Supply voltage with Feedback function contact 30 voltage (AI_30)	6	Contact 31 / GND
3	LIN bus, activatable via DO_LIN_EN	7	CAN-H
4	Contact 15 ignition or optionally usable as analog or digital input, see page 2	9	CAN-L

PIN ASSIGNMENT INPUTS AND OUTPUTS

Pin	Signal	Description	Pin	Signal	Description
1	AI_X DI_X	Analog input X 0...14.3 V or digital input	5	AI_OUT2 DI_OUT2 DO_OUT2 PWM_OUT2	Analog input OUT2 0...33 V or digital input OUT 2 or digital input OUT2 with PWM option
4	AI_15 DI_15	Analog input 5 0...11 V or digital input	8	AI_OUT1 DI_OUT1 DO_OUT1 PWM_OUT1	Analog input OUT1 0...33 V or digital input OUT1 or digital input OUT1 with PWM option

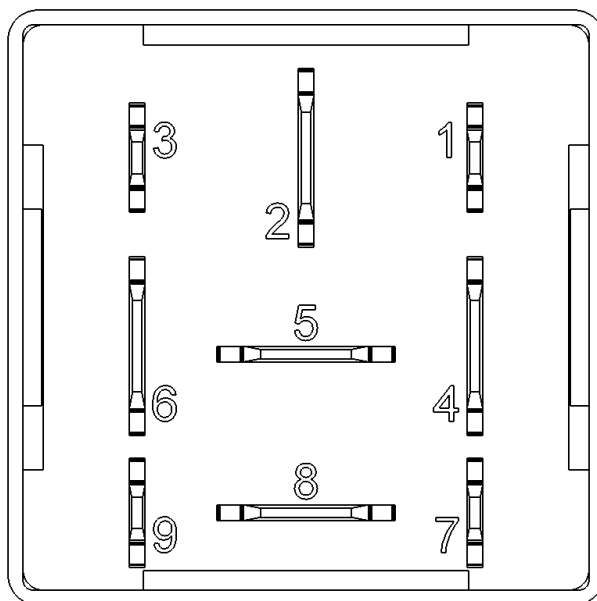

view of plug

PIN FEATURE MAP

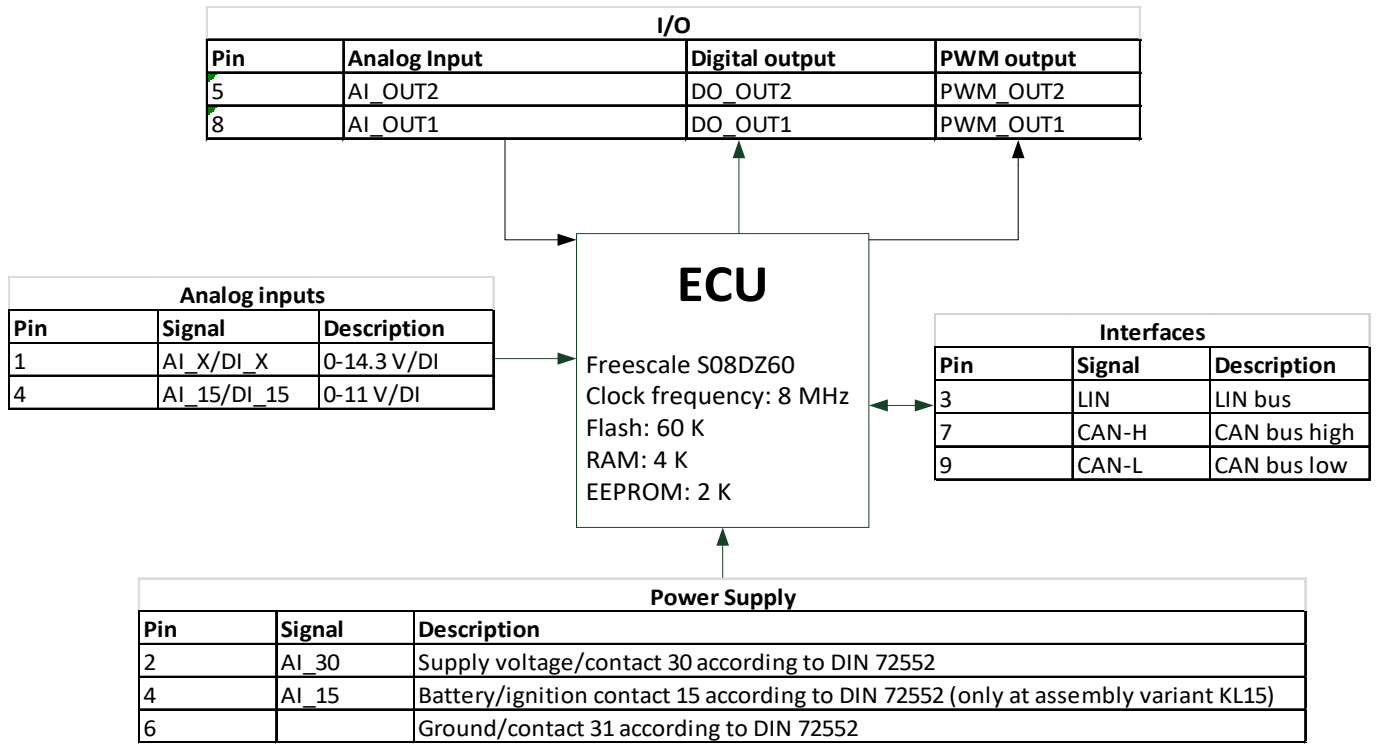

BLOCK FUNCTION DIAGRAM

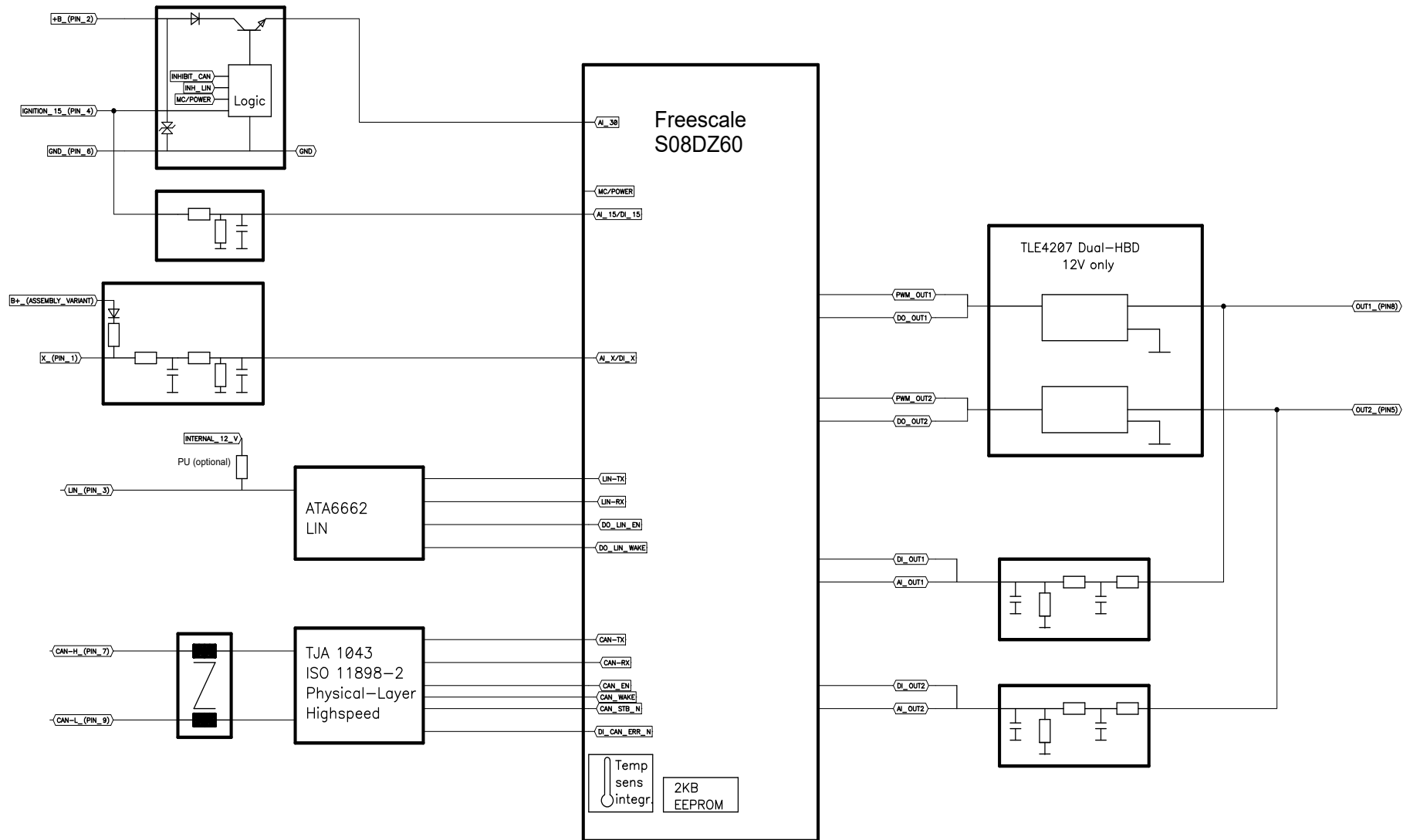

TECHNICAL DRAWING IN MM [INCH]

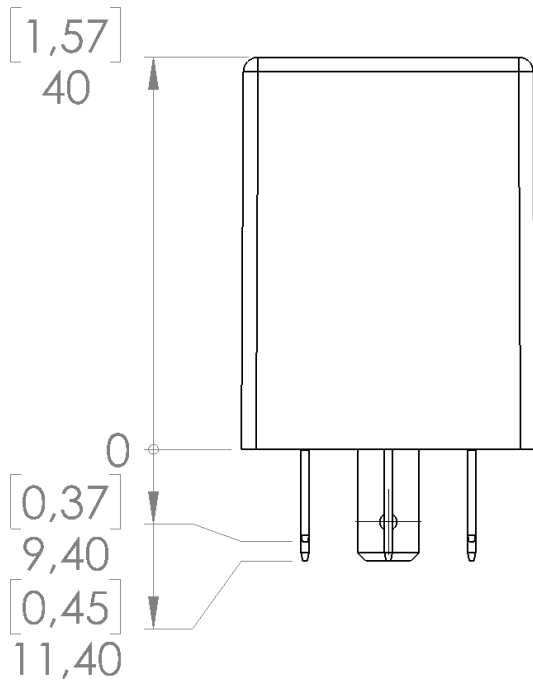

front view

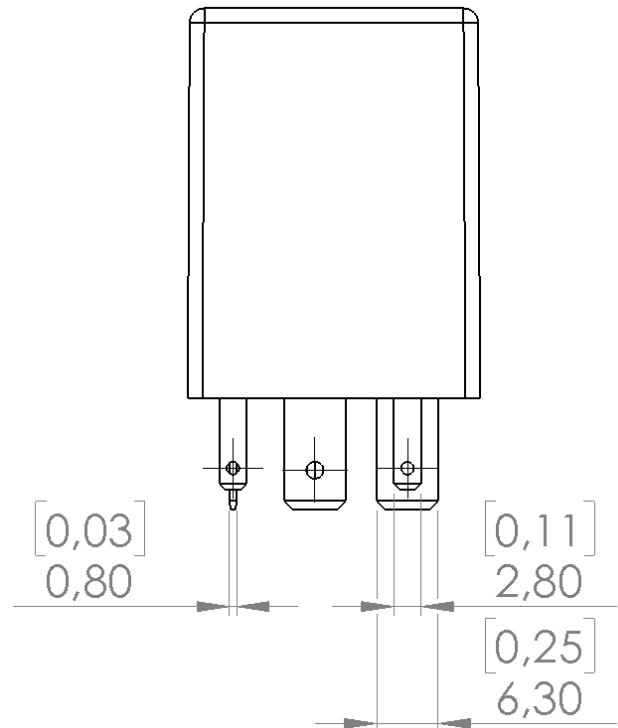

side view

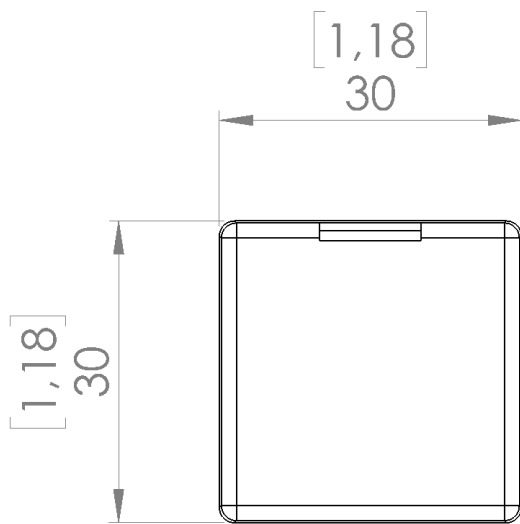

aerial view

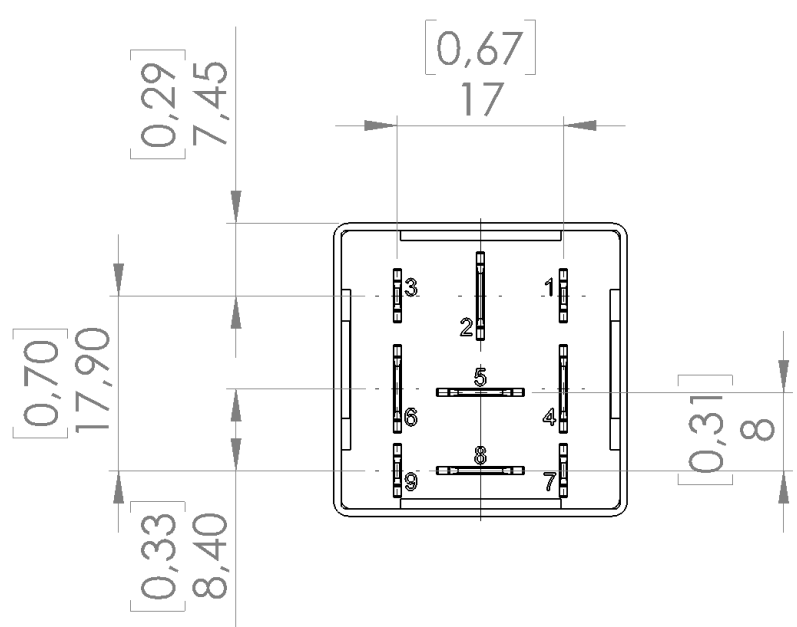

bottom view

ASSEMBLY OPTIONS AND ORDER INFORMATION

Order number	Inputs					Outputs	Interfaces			Remarks
	A Voltage 0...14.3 V	B Digital input	C Voltage 0...11 V	D Frequency Hz	E Voltage 0...14.3 V 20 kΩ Pull-up included		F I/O's (optionally as analog / digital input or digital output with PWM option)	CAN bus		
1.113.111.00		1,4	4		1	5,8	X	X		LIN without Pull-up (Slave)
1.113.111.03		1,4	4		1	5,8	X	X		LIN with 1 kΩ Pull-up (Master)
1.113.111.04	1	1,4	4	1		5,8	X	X		LIN without Pull-up (Slave)

SCIP-number: e1c196ec-d6dc-4ab6-9abc-0c1b885d438b

ACCESSORIES

Description	Order number
Softwaretool MRS Applies Studio	1.100.200.01
Cable set to program for Micro PLC CAN LIN Gateway	109446
Connector package watertight 40 mm	1.017.010.40
Socket	1.017.002.00
FASTON terminal for latching 2.8 mm 0.5-1.0 mm ²	105292
FASTON terminal for latching 6.3 mm 1 mm ²	102355
FASTON terminal for latching 6.3 mm 1.5-2.5 mm ²	103064
PCAN-USB Interface	105358



MANUFACTURER

MRS Electronic GmbH & Co. KG
 Klaus-Gutsch-Str. 7
 78628 Rottweil
 Germany

NOTES ON WIRING AND CABLE ROUTING

PWM outputs may not be connected with each other or bypassed.

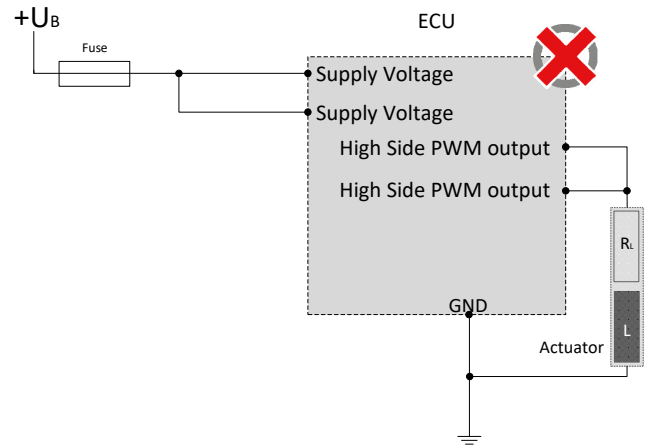
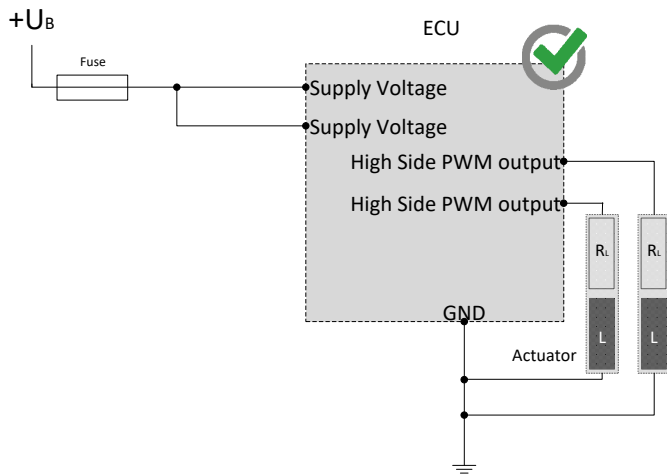

The pins (I/Os) can be used in combination and may not be switched externally against a higher voltage level than supply voltage.

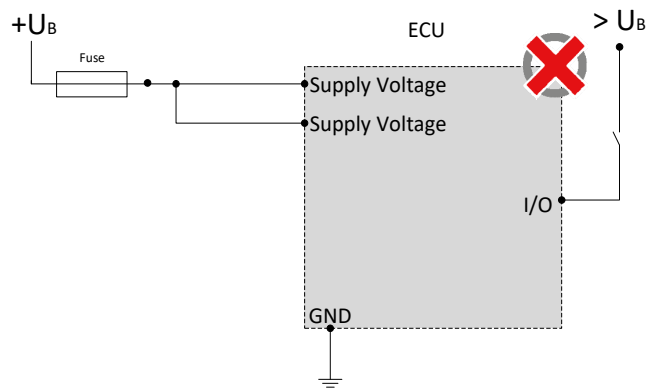
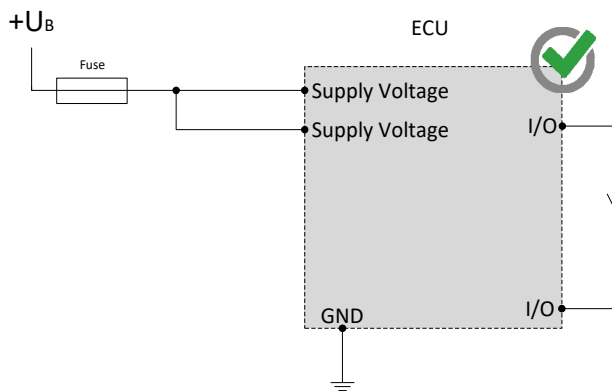

NOTES ON WIRING AND CABLE ROUTING

Hightside outputs may only be switched to ground.

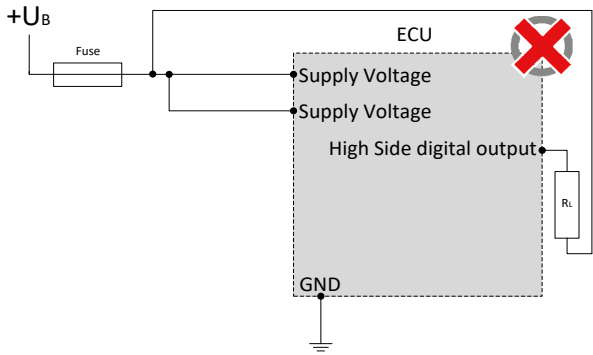
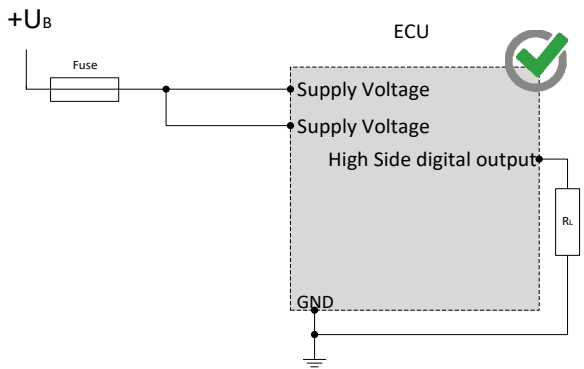
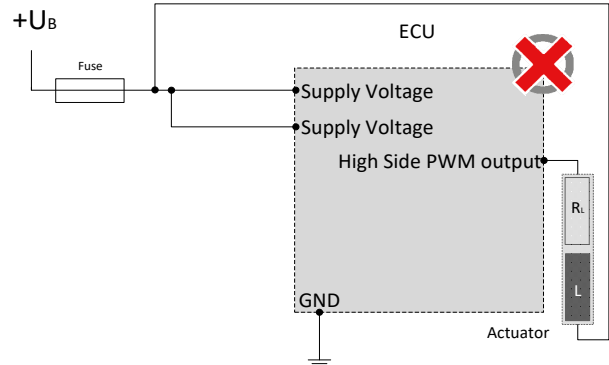
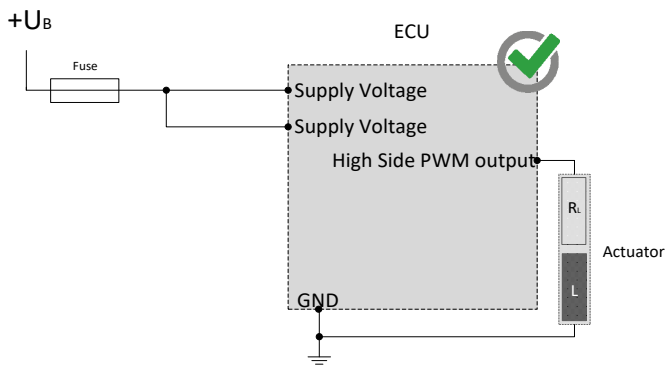

CAN bus communication is the main communication between the control unit and the vehicle. Therefore, connect the CAN bus with special care and check the correct communication with the vehicle to avoid undesired behavior.

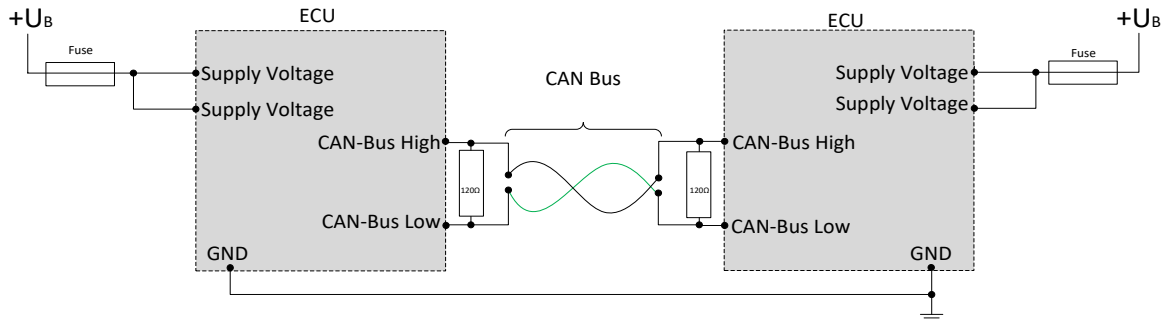

SAFETY AND INSTALLATION INFORMATION

It is essential to read the instructions in full thoroughly before working with the device.

Please note and comply with the instructions in the operating instructions and the information in the device data sheet, see www.mrs-electronic.com

Staff qualification: Only staff with the appropriate qualifications may work on this device or in its proximity.

SAFETY



WARNING! Danger as a result of a malfunction of the entire system.

Unforeseen reactions or malfunctions of the entire system may jeopardise the safety of people or the machine.

- Ensure that the device is equipped with the correct software and that the wiring and settings on the hardware are appropriate.



WARNING! Danger as a result of unprotected moving components.

Unforeseen dangers may occur from the entire system when putting the device into operation and maintaining it.

- Switch the entire system off before carrying out any work and prevent it from unintentionally switching back on.
- Before putting the device into operation, ensure that the entire system and parts of the system are safe.
- The device should never be connected or separated under load or voltage.



CAUTION! Risk of burns from the housing.

The temperature of the device housing may be elevated.

- Do not touch the housing and let all system components cool before working on the system.

PROPER USE

The device is used to control or switch one or more electrical systems or sub-systems in motor vehicles and machines and may only be used for this purpose. The device may only be used in an industrial setting.



WARNING! Danger caused by incorrect use.

The device is only intended for use in motor vehicles and machines.

- Use in safety-related system parts for personal protection is not permitted.
- Do not use the device in areas where there is a risk of explosion.

Correct use:

- operating the device within the operating areas specified and approved in the associated data sheet.
- strict compliance with these instructions and no other actions which may jeopardise the safety of individuals or the functionality of the device.

Obligations of the manufacturer of entire systems

It is necessary to ensure that only functional devices are used. If devices fail or malfunction, they must be replaced immediately.

System developments, installation and the putting into operation of electrical systems may only be carried out by trained and experienced staff who are sufficiently familiar with the handling of the components used and the entire system.

It is necessary to ensure that the wiring and programming of the device does not lead to safety-related malfunctions of the entire system in the event of a failure or a malfunction. System behaviour of this type can lead to a danger to life or high levels of material damage.

The manufacturer of the entire system is responsible for the correct connection of the entire periphery (e.g. cable cross sections, correct selection/connection of sensors/actuators).

Opening the device, making changes to the device and carrying out repairs are all prohibited. Changes or repairs made to the cabling can lead to dangerous malfunctions. Repairs may only be carried out by MRS.

Installation

The installation location must be selected so the device is exposed to as low a mechanical and thermal load as possible. The device may not be exposed to any chemical loads.

Install the device in such a manner that the plugs point downwards. This means condensation can flow off the device. Single seals on the cables/leads must be used to ensure that no water gets into the device.

Putting into operation

The device may only be put into operation by qualified staff. This may only occur when the status of the entire system corresponds to the applicable guidelines and regulations.

FAULT CORRECTION AND MAINTENANCE



NOTE The device is maintenance-free and may not be opened.

- If the device has damage to the housing, latches, seals or flat plugs, it must be taken out of operation.

Fault correction and cleaning work may only be carried out with the power turned off. Remove the device to correct faults and to clean it.

Check the integrity of the housing and all flat plugs, connections and pins for mechanical damage, damage caused by overheating, insulation damage and corrosion. In the event of faulty switching, check the software, switches and settings.

Do not clean the device with high pressure cleaners or steam jets. Do not use aggressive solvents or abrasive substances.