

mounting direction

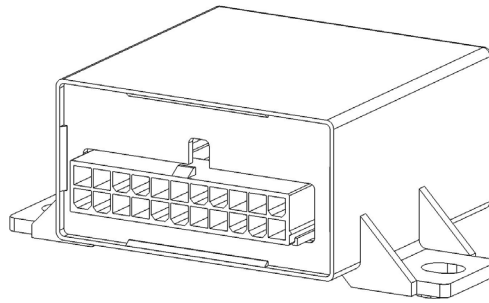

view of plug

## DESCRIPTION

The compact CAN I/O controller in the lowside and highside version offers four additional lowside outputs in addition to the standard four highside outputs. The perfect solution for controlling mass-controlled actuators and motor bridges.

## TECHNICAL SPECIFICATION

Housing	Plastic
Connector	22 pin Molex Mini Fit Junior
Weight	75 g
Temperature range (according to ISO 16750-4)	-40 to +85 °C (at +85 °C rated power see page 4)
Environmental protection	IP53
Current consumption	30 mA
Over-current Protection	20 A
Total Inputs and outputs	14 (6 inputs, 8 I/O's)
Inputs	<b>Configurable as:</b> Digital, positive encoder signal analog (0...11.4 / 33.68 V)
Outputs	<b>Configurable as:</b> Digital, positive switching (high side) Digital, negative switching (low side)
Operating voltage	9–32 V 12 V (Code B) and 24 V (Code E) ISO 16750–2 compliant
Overvoltage protection	≥ 33 V
Quiescent current	@ 12 V = 150 µA @ 24 V = 200 µA
Reverse polarity protection	Yes
CAN Interfaces	CAN bus interface 2.0 A/B, ISO 11898 compliant

## REGULATORY APPROVALS AND TESTING

CE conformity	compliant
E1 approval	10 R - 06 8369
Electrical tests	According to ISO 16750 - 2: Short circuit protection Reverse polarity protection Interruption pin and connector Overvoltage at +65 °C Operation and storage test at T <sub>min</sub> and T <sub>max</sub> Superimposed alternating voltage Slowly decrease and increase of supply voltage Momentary drop in supply voltage Reset behaviour at voltage drop Moist Heat
	According to ISO 7637-2: Pulse 1, 2a, 2b, 3a, 3b

## SOFTWARE/PROGRAMMING

Programming System	<b>MRS APPLICS STUDIO</b> The Applics Studio is the new development and tool platform for our assemblies. Program your MRS controls quickly and easily with our stand-alone software. The focus is on your application.
--------------------	--

## INPUT FEATURES - SUMMARY

<b>Pin 3, 5, 6</b>	Usable as analog input Resolution Accuracy	12 Bit $\pm 1\%$ full scale	<b>Pin 13, 14, 15, 16</b>	Usable as analog or digital input Resolution Accuracy	12 Bit $\pm 1\%$ full scale
Voltage input 0...11.4 V (see <a href="#">A</a> )	Input resistance Input frequency Accuracy	22.6 $\pm$ 0.5 k $\Omega$ $f_c^* = 55$ Hz $\pm 3\%$	Voltage input 0...11.4 V (see <a href="#">E</a> )	Input resistance Input frequency Accuracy	15.6 $\pm$ 0.5 k $\Omega$ $f_c^* = 55$ Hz 3 %
Digital input positive (see <a href="#">A</a> )	Input resistance Input frequency Turn-on threshold Turn-off threshold	22.6 $\pm$ 0.5 k $\Omega$ $f_c^* = 55$ Hz 6.5 $\pm$ 0.2 V 4.5 $\pm$ 0.2 V	Digital input positive (see <a href="#">E</a> )	Input resistance Input frequency Turn-on threshold Turn-off threshold	15.6 $\pm$ 0.5 k $\Omega$ $f_c^* = 60$ Hz 6.5 $\pm$ 0.2 V 4.5 $\pm$ 0.2 V
<b>Pin 2</b>	Usable as analog or digital input Resolution Accuracy	12 Bit $\pm 1\%$ full scale	<b>Pin 18, 19</b>	Usable as analog or digital input Resolution Accuracy	12 Bit $\pm 1\%$ full scale
Voltage input 0...33.68 V (see <a href="#">B</a> )	Input resistance Input frequency Accuracy	66.6 k $\Omega$ $f_c^* = 40$ Hz $\pm 3\%$	Voltage input 0...11.4 V (see <a href="#">E</a> )	Input resistance Input frequency Accuracy	22.6 $\pm$ 0.5 k $\Omega$ $f_c^* = 55$ Hz 3 %
Digital input Positive (see <a href="#">B</a> )	Input resistance Input frequency Turn-on threshold Turn-off threshold	66.6 k $\Omega$ $f_c^* = 40$ Hz 19 V 14 V	Digital input positive (see <a href="#">E</a> )	Input resistance Input frequency Turn-on threshold Turn-off threshold	22.6 $\pm$ 0.5 k $\Omega$ $f_c^* = 60$ Hz 6.5 $\pm$ 0.2 V 4.5 $\pm$ 0.2 V
<b>Pin 4, 7</b>	Usable as analog or digital input Resolution Accuracy	12 Bit $\pm 1\%$ full scale	<b>Pin 20, 21</b>	Usable as digital input Resolution Accuracy	12 Bit $\pm 1\%$ full scale
Voltage input 0...11.4 V (see <a href="#">A</a> )	Input resistance Input frequency Accuracy	22.6 $\pm$ 0.5 k $\Omega$ $f_c^* = 55$ Hz 3 %	Digital input Positive (see <a href="#">E</a> )	Input resistance Input frequency Turn-on threshold Turn-off threshold	22.6 $\pm$ 0.5 k $\Omega$ $f_c^* = 55$ Hz 6.5 $\pm$ 0.2 V 4.5 $\pm$ 0.2 V
Digital input Positive (see <a href="#">A</a> )	Input resistance Input frequency Turn-on threshold Turn-off threshold	22.6 $\pm$ 0.5 k $\Omega$ $f_c^* = 55$ Hz 6.5 $\pm$ 0.2 V 4.5 $\pm$ 0.2 V			
Frequency input (see <a href="#">D</a> )	Input resistance Input frequency Turn-on threshold Turn-off threshold	22.6 $\pm$ 0.5 k $\Omega$ $\pm 3\%$ accuracy at $\leq 2.2$ kHz 6.5 $\pm$ 0.2 V 4.5 $\pm$ 0.2 V			

\* $f_c^*$  = cutoff frequency (-3 dB)

OUTPUT FEATURES - SUMMARY

<b>Pin 13, 14 HSD</b>	Protective circuit for inductive loads	Optionally integrated	<b>Pin 18, 19, 20, 21 LSD</b>	Digital, negative switching (low side, see E)	Switching voltage Switching current	9-32 V DC see load test page 4
	Wire fault diagnostics	Possible via current sense				
	Short circuit diagnostics	Possible via current sense				
	Digital, positive switching (high side, see E)	Switching voltage Switching current				
Short circuit protection against GND and U <sub>B</sub>	Internal overtemperature protection, latch-off can be realized by software application		Short circuit protection against GND and U <sub>B</sub>	Internal overtemperature protection, latch-off can be realized by software application		
<b>Pin 15, 16 HSD</b>	Protective circuit for inductive loads	Optionally integrated	Information about contacting LED's to LSD	Leakage current (depends on LSD driver)	≤ 150 µA	
	Wire fault diagnostics	Possible via current sense				
	Short circuit diagnostics	Possible via current sense				
	Digital, positive switching (high side, see E)	Switching voltage Switching current Conversion factor Current sense				9-32 V DC 0.02-2.5 A 1 Digit ± 2.26 mA
	PWM-output (see E)	Output frequency Duty cycle Resolution Switching current				500 Hz 0...1000 % 1 % see load test page 4
		Timer Channel				1
	Short circuit protection against GND and U <sub>B</sub>	Internal overtemperature protection, latch-off can be realized by software application				

## LOAD TESTS

**Load test at +85 °C without PWM**

	Outputs	Load	Endurance
Load tests at +85 °C (Digital outputs)	4 HSD channels	4 x 2.5 A	Continuous
	4 HSD channels	2 x 2 A; 2 x 4 A	30 minutes
	4 HSD channels	2 x 2.5 A; 2 x 3.5 A	10 minutes
	2 HSD channels	2 x 5 A	5 minutes
	1 HSD channel	1 x 6 A	10 minutes

**Load test at +80 °C with PWM**

	Outputs	Load	Endurance
Load tests at +80 °C (PWM outputs with frequency f=200 Hz and 90 % duty cycle)	4 HSD channels	4 x 2.0 A	Continuous
	4 HSD channels	4 x 2.5 A	15 minutes
	4 HSD channels	1 x 3.5 A; 3 x 2.5 A	2 minutes
	2 HSD channels	2 x 3.5 A	2 minutes
	1 HSD channel	1 x 5 A	Continuous

**Load test at +85 °C with PWM**

	Outputs	Load	Endurance
Load tests at +85 °C (PWM outputs with frequency f=1 kHz and 90 % duty cycle)	4 HSD channels	4 x 1 A	Continuous
	4 HSD channels	4 x 1.5 A	1 minutes
	2 HSD channels	2 x 2.5 A	5 minutes
	1 HSD channel	1 x 3.5 A	30 minutes

**Load test at +85 °C without PWM**

	Outputs	Load	Total load (ohmic)
Load tests at +85 °C (max. load per output without PWM)	4 LSD and 4 HSD channels	8 x 2 A	16.0 A
	1 LSD channel	1 x 5.4 A	5.4 A
	2 LSD channels	2 x 3.95 A	7.9 A
	3 LSD channels	2 x 3.25 A	9.75 A
	4 LSD channels	4 x 2.6 A	10.4 A

**Load test at +85 °C with PWM**

	Outputs	Load	Total load
Load tests at +85 °C (max. load per output with PWM 1kHz, 97 % duty cycle)	1 LSD channel	1 x 4.55 A ohmic	4.55 A
	1 LSD channel	1 x 3.15 A inductive	3.15 A
	2 LSD channels	2 x 2.25 A inductive	4.5 A
	3 LSD channels	3 x 1.65 A inductive	4.95 A
	4 LSD channels	4 x 1.5 A inductive	6.0 A
	All channels	LSD 2 x 1.3 A, 2 x 2 A; HSD 2 x 1.3 A, 2 x 2 A (static)	13.2 A
	All channels	LSD 4 x 1.5 A; HSD 4 x 1.36 A (2 of them static)	11.4 A

PIN ASSIGNMENT POWER SUPPLY AND INTERFACES

Pin	Description	Pin	Description
1	Ground / contact 31 according to DIN 72552	9	CAN bus high
8	Battery/ignition contact 15 according to DIN 72552	10	CAN bus low
12	Supply voltage	11	RS 485 - A / CAN bus high / ground (assembly option, otherwise not connected)
17	Ground	22	RS-485 - B / CAN bus low / LIN (assembly option, otherwise not connected)

PIN ASSIGNMENT INPUTS AND OUTPUTS

Pin	Signal	Description	Pin	Signal	Description
2	AI_5 DI_AI_5	Analog input 5; 0-33.68 V can also be used as digital input	15	AI_OUT2 / DI_AI_OUT2 DO_PWM_OUT2 AI_SNS2 PWM_OUT2	Analog/digital input IO2; 0-11.4 V or digital output DO2 with status feedback and PWM capability
3	AI_4 DI_AI_4	Analog input 4; 0-11.4 V can also be used as digital input	16	AI_OUT3 / DI_AI_OUT3 DO_PWM_OUT3 AI_SNS3 PWM_OUT3	Analog/digital input IO3; 0-11.4 V or digital output DO3 with status feedback and PWM capability
4	AI_3 DI_AI_3	Analog input 3; 0-11.4 V can also be used as digital input	18	AI_OUT4 / DI_AI_OUT4 DO_PWM_OUT4 PWM_OUT4	Analog/digital input IO4; 0-11.4 V or digital output DO4 with PWM capability
5	AI_2 DI_AI_2	Analog input 2; 0-11.4 V can also be used as digital input	19	AI_OUT5 / DI_AI_OUT5 DO_PWM_OUT5 PWM_OUT5	Analog/digital input IO5; 0-11.4 V or digital output DO5 with PWM capability
6	AI_1 DI_AI_1	Analog input 1; 0-11.4 V can also be used as digital input	20	DI_AI_OUT6 DO_PWM_OUT6 PWM_OUT6	Digital input IO6; 0-11.4 V or digital output DO6 with PWM capability
7	AI_0 DI_AI_0	Analog input 0; 0-11.4 V can also be used as digital input	21	DI_AI_OUT7 DO_PWM_OUT7 PWM_OUT7	Digital input IO7; 0-11.4 V or digital output DO7 with PWM capability
13	AI_OUT0 / DI_OUT0 DO_OUT0 AI_SNS0	Analog/digital input IO0; 0-11.4 V or digital output DO0 with status feedback			
14	AI_OUT1 / DI_OUT1 DO_OUT1 AI_SNS1	Analog/digital input IO1; 0-11.4 V or digital output DO1 with status feedback			

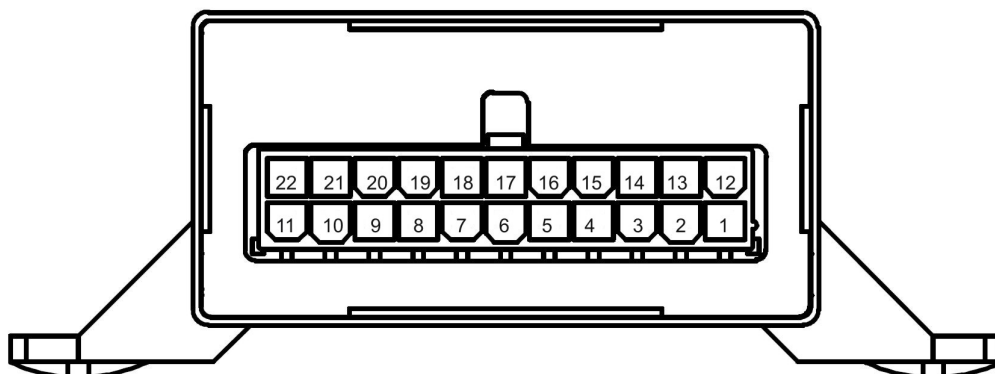

PIN FEATURE MAP

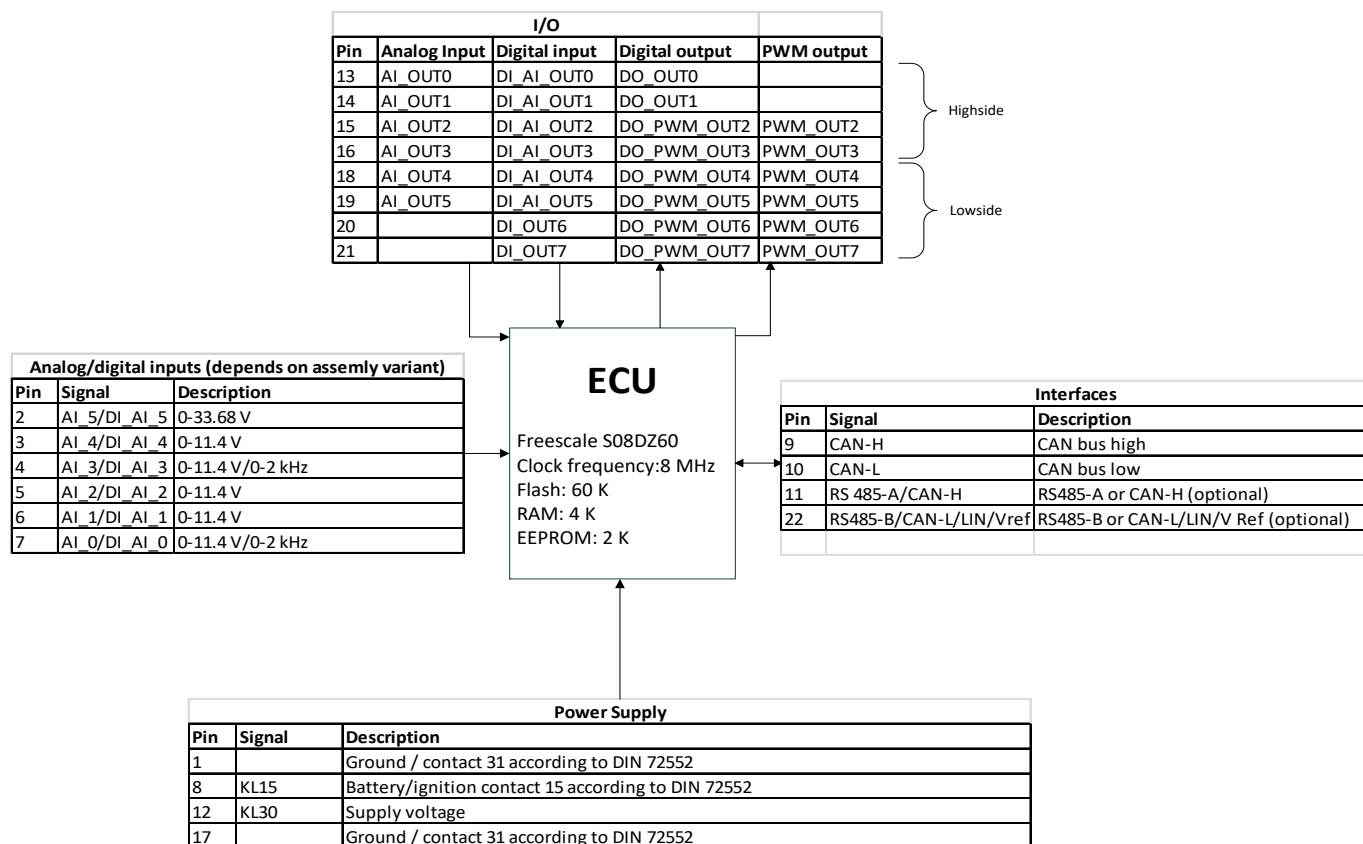



TECHNICAL DRAWING IN MM [INCH], TOLERANCES ACCORDING TO ISO 2768-1 V

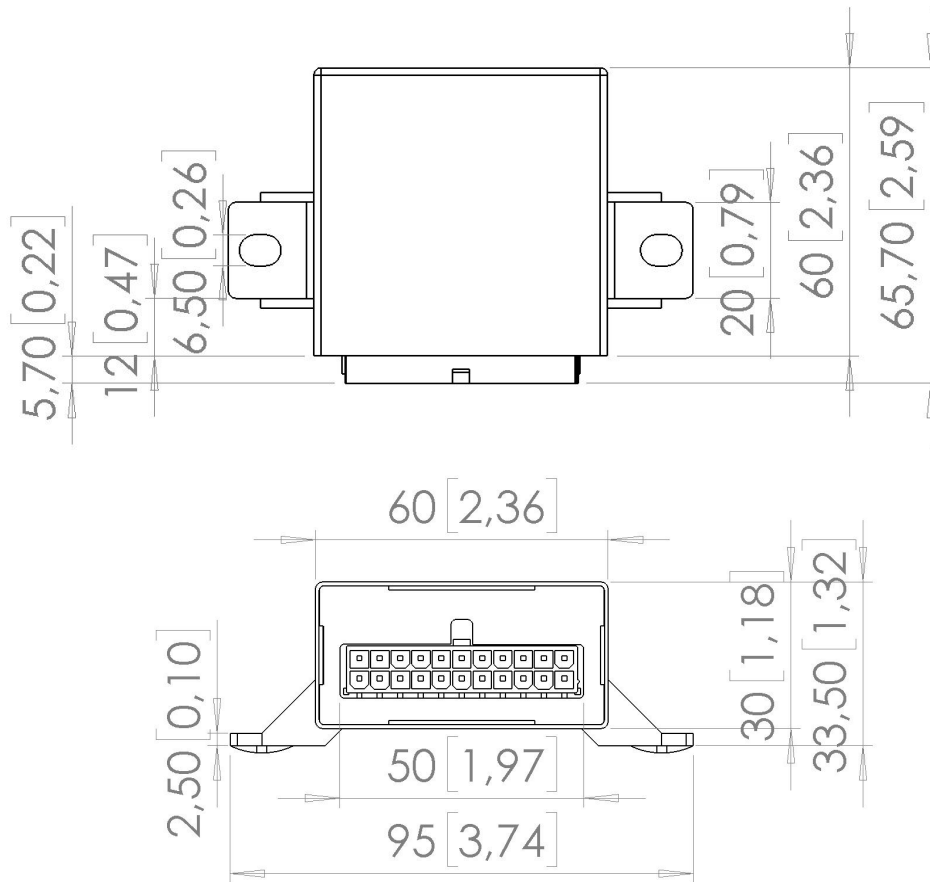

ASSEMBLY OPTIONS AND ORDER INFORMATION

Order number	Inputs					Outputs		CAN bus	Features
	A Voltage 0 – 11.4 V	B Voltage 0 – 33 V	C Current 0 - 24 mA	D Frequency Hz	Sensor inputs  10 kΩ pull-up PT1000 Sensor 1 kΩ pull-up	E I/O's (can be used as analog or digital inputs or as digital outputs)	F PWM ≤ 500 Hz		
<b>1.129.300.0001</b>	3,4,5,6,7	2				13,14,15,16,18,19,20,21	15,16,18,19,20,21	X	5 V Ref
<b>1.129.301.0001</b>	3,4,5,6,7	2		4,7		13,14,15,16,18,19,20,21	15,16,18,19,20,21	X	-
<b>1.129.312.0001</b>	3,4,5,6,7	2		4,7		13,14,15,16,18,19,20,21	15,16,18,19,20,21	X	LIN (Slave)
<b>1.129.322.0001</b>	3,4,5,6,7	2		4,7		13,14,15,16,18,19,20,21	15,16,18,19,20,21	X	LIN (Master)

SCIP-numbers	
<b>1.129.300.0001</b>	b09ab02d-f10c-47c9-bace-554d75257de8
<b>1.129.301.0001</b>	bbb921ff-f2aa-4202-9b03-21a335f749fd
<b>1.129.312.0001</b>	bbb921ff-f2aa-4202-9b03-21a335f749fd
<b>1.129.322.0001</b>	bbb921ff-f2aa-4202-9b03-21a335f749fd

ACCESSORIES

Description	Order number
Softwaretool MRS Applics Studio	1.100.200.01
Cable set CAN I/O LSD	106817
Connector package CAN I/O LSD	106940
PCAN-USB Interface	105358



MANUFACTURER

MRS Electronic GmbH & Co. KG  
 Klaus-Gutsch-Str. 7  
 78628 Rottweil

NOTES ON WIRING AND CABLE ROUTING

The electronic system and the power outputs of a control unit must be supplied by the same power supply system.

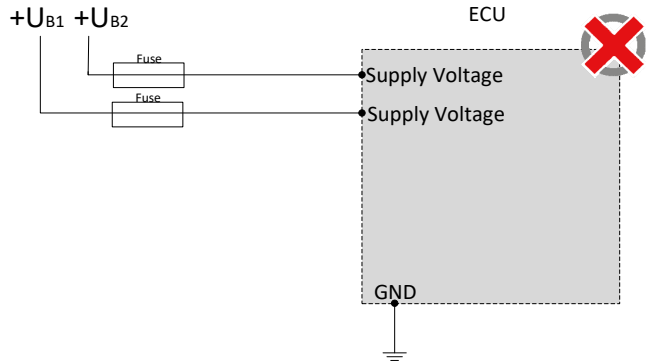
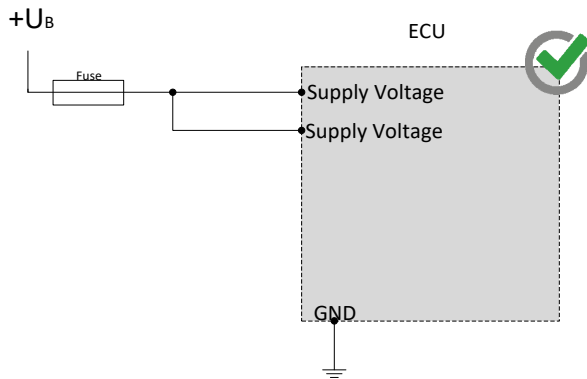

PWM outputs may not be connected with each other or bypassed.

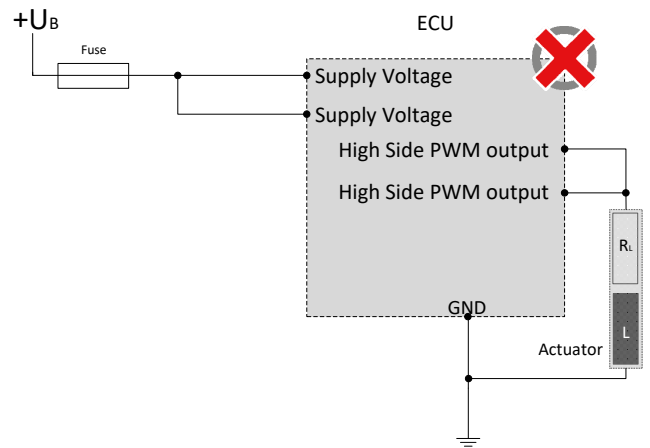
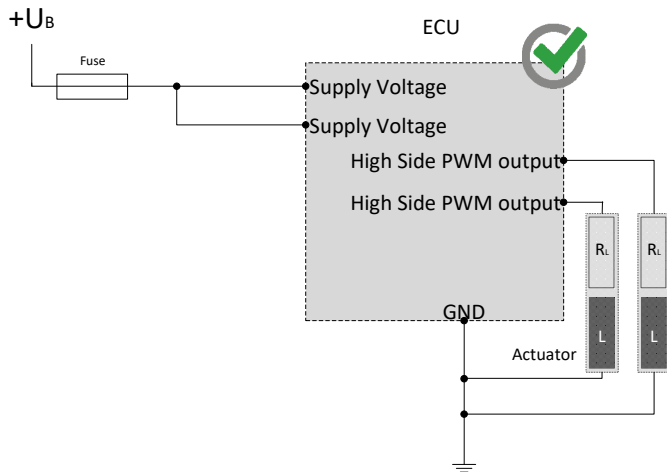

The pins (I/Os) can be used in combination and may not be switched externally against a higher voltage level than supply voltage.

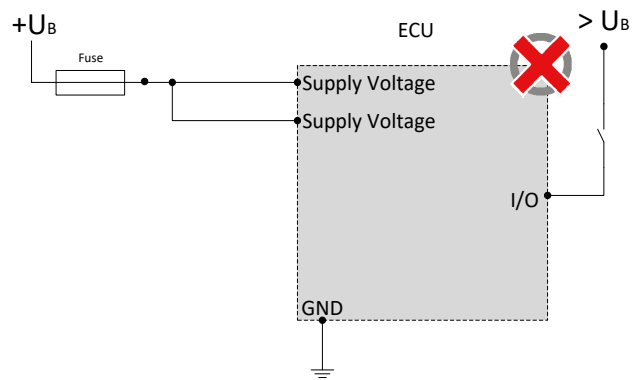
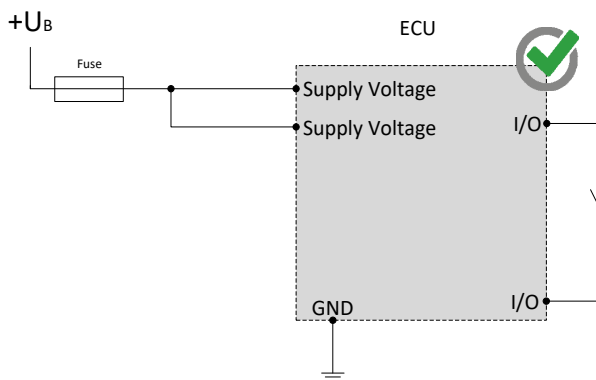

NOTES ON WIRING AND CABLE ROUTING

Hightside outputs may only be switched to ground.

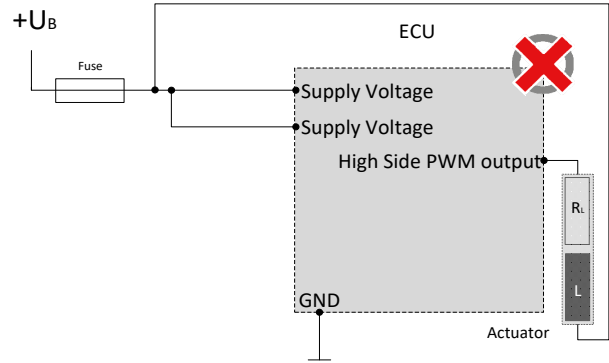
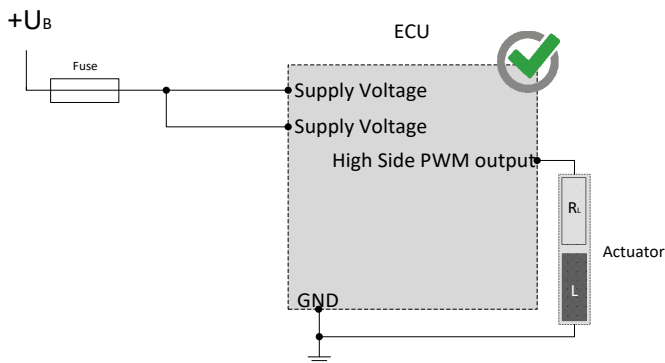

Lowside outputs may only be switched to supply voltage.

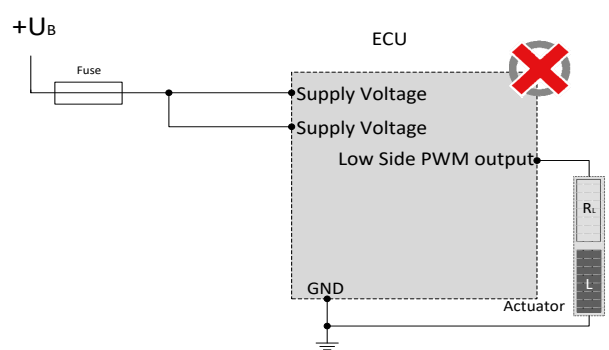
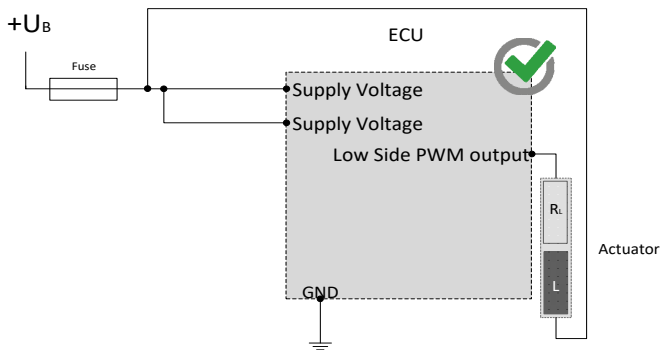

The sensor supplies can be "lifted" through an external circuitry, for example the creation of higher voltage, as they only work as a voltage source but not as voltage drain. The lift of a voltage source may lead to unforeseen malfunctions and damages of the control unit in case of permanent operation.

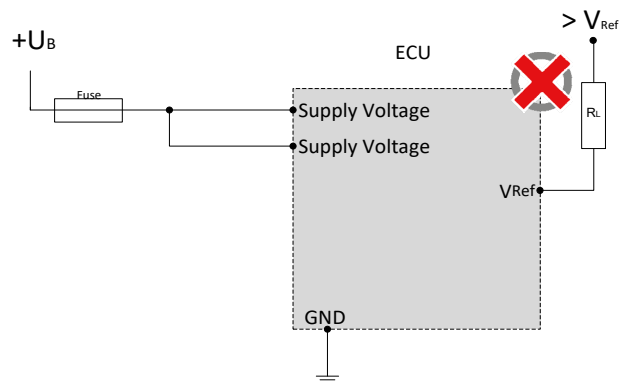
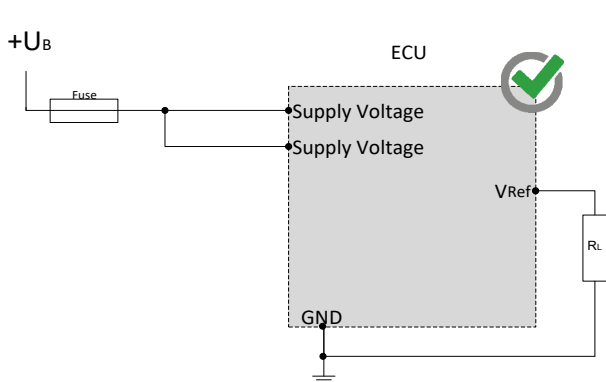

CAN bus communication is the main communication between the control unit and the vehicle. Therefore, connect the CAN bus with special care and check the correct communication with the vehicle to avoid undesired behavior.

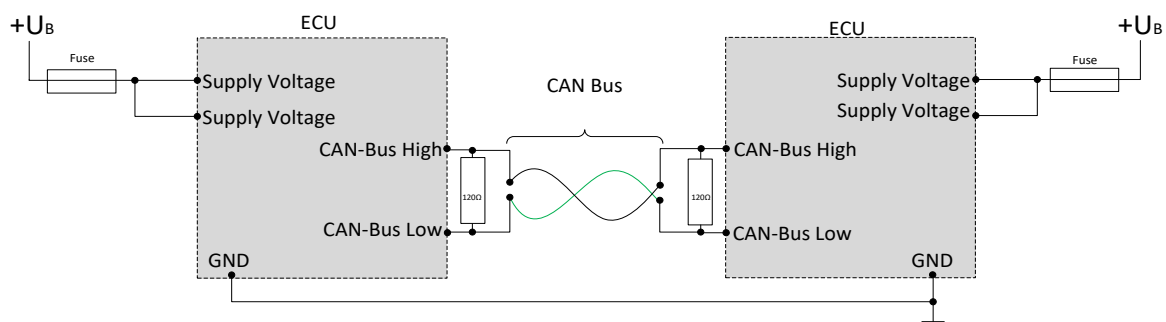

## SAFETY AND INSTALLATION INFORMATION

It is essential to read the instructions in full thoroughly before working with the device.

Please note and comply with the instructions in the operating instructions and the information in the device data sheet, see [www.mrs-electronic.com](http://www.mrs-electronic.com)

**Staff qualification:** Only staff with the appropriate qualifications may work on this device or in its proximity.

### SAFETY



**WARNING! Danger as a result of a malfunction of the entire system.**

Unforeseen reactions or malfunctions of the entire system may jeopardise the safety of people or the machine.

- Ensure that the device is equipped with the correct software and that the wiring and settings on the hardware are appropriate.



**WARNING! Danger as a result of unprotected moving components.**

Unforeseen dangers may occur from the entire system when putting the device into operation and maintaining it.

- Switch the entire system off before carrying out any work and prevent it from unintentionally switching back on.
- Before putting the device into operation, ensure that the entire system and parts of the system are safe.
- The device should never be connected or separated under load or voltage.



**CAUTION! Risk of burns from the housing.**

The temperature of the device housing may be elevated.

- Do not touch the housing and let all system components cool before working on the system.

### PROPER USE

The device is used to control or switch one or more electrical systems or sub-systems in motor vehicles and machines and may only be used for this purpose. The device may only be used in an industrial setting.



**WARNING! Danger caused by incorrect use.**

The device is only intended for use in motor vehicles and machines.

- Use in safety-related system parts for personal protection is not permitted.
- Do not use the device in areas where there is a risk of explosion.

**Correct use:**

- operating the device within the operating areas specified and approved in the associated data sheet.
- strict compliance with these instructions and no other actions which may jeopardise the safety of individuals or the functionality of the device.

**Obligations of the manufacturer of entire systems**

It is necessary to ensure that only functional devices are used. If devices fail or malfunction, they must be replaced immediately.

System developments, installation and the putting into operation of electrical systems may only be carried out by trained and experienced staff who are sufficiently familiar with the handling of the components used and the entire system.

It is necessary to ensure that the wiring and programming of the device does not lead to safety-related malfunctions of the entire system in the event of a failure or a malfunction. System behaviour of this type can lead to a danger to life or high levels of material damage.

The manufacturer of the entire system is responsible for the correct connection of the entire periphery (e.g. cable cross sections, correct selection/connection of sensors/actuators).

Opening the device, making changes to the device and carrying out repairs are all prohibited. Changes or repairs made to the cabling can lead to dangerous malfunctions. Repairs may only be carried out by MRS.

**Installation**

The installation location must be selected so the device is exposed to as low a mechanical and thermal load as possible. The device may not be exposed to any chemical loads.

Install the device in such a manner that the plugs point downwards. This means condensation can flow off the device. Single seals on the cables/leads must be used to ensure that no water gets into the device.

**Putting into operation**

The device may only be put into operation by qualified staff. This may only occur when the status of the entire system corresponds to the applicable guidelines and regulations.

### FAULT CORRECTION AND MAINTENANCE



**NOTE The device is maintenance-free and may not be opened.**

- If the device has damage to the housing, latches, seals or flat plugs, it must be taken out of operation.

Fault correction and cleaning work may only be carried out with the power turned off. Remove the device to correct faults and to clean it.

Check the integrity of the housing and all flat plugs, connections and pins for mechanical damage, damage caused by overheating, insulation damage and corrosion. In the event of faulty switching, check the software, switches and settings.

Do not clean the device with high pressure cleaners or steam jets. Do not use aggressive solvents or abrasive substances.