

mounting direction

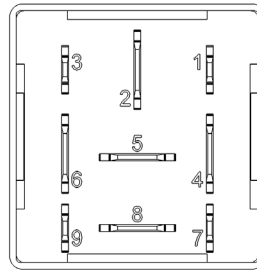

view of plug

## DESCRIPTION

The new Micro Gateway is a compact gateway for automotive applications. The core piece, the 32-bit processor, provides you with higher performance and thus secure routing and gateway functionality at high bus loads. The 2 I/Os are now also PWM capable. Implement larger and more complex programs and applications by increasing the flash memory to 2 MB. The RAM has also been increased from 12 KB to 256 KB.

## TECHNICAL DATA

Housing	Plastic PA 66GF30
Connector	Base plate 9-pin
Weight	30 g
Temperature range acc. to ISO 16750-4	-40 °C...+85 °C
Environmental protection acc. to ISO 20653	IP6K8 with correct mounting direction and use of the waterproof plug-in socket
Over-current protection	1 A + Load
Total Inputs and outputs	Variant with I/O: 2 Variant without I/O: 0
Inputs	<b>Depending on assembly options:</b> Analog input 0...33 V Digital input
Outputs	<b>Configurable as:</b> Digital, positive switching (high side) PWM output (3 Hz...1000 Hz)
Supply voltage	9...32 V (Code C for 12 V, Code E for 24 V, acc. to ISO 16750-2); variants with LIN 15...32 V (Code F, acc. to ISO 16750-2) (see. <a href="#">p. 6</a> )
Overvoltage protection	≥ 33 V
Current consumption	70 mA
Quiescent current	80 µA at 12 V 100 µA at 24 V
Reverse polarity protection	yes
CAN interface	CAN Interface 2.0 A/B, ISO 11898-2; CAN-FD-capable

## SOFTWARE/PROGRAMMING

### MRS APPLICS STUDIO

The Applics Studio is the new development and tool platform for our assemblies. Program your MRS controls quickly and easily with our stand-alone software. The focus is on your application.

## REGULATORY APPROVALS AND TESTING

E1 approval	10 R - 06 9178
Electrical tests	<b>Acc. to ISO 16750-2 or -4:</b> Short circuit protection Reverse polarity Ground offset Interruption pin and connector Long-term overvoltage at $T_{max}$ -20 °C Storage test at $T_{max}$ and $T_{min}$ Operation test at $T_{max}$ and $T_{min}$ Start impulse (formerly. pulse 4 acc. to ISO 7637) Load dump for 24 V (RI=4Ω)  <b>Acc. to ISO 7637-2:</b> Pulse 1, 2a, 2b, 3a, 3b, severity level III  <b>Acc. to ISO 10605:</b> ESD contact discharge Housing/pins: testing severity 2 Discharge islands: testing severity 3 ESD air discharge: Housing: testing severity 3  <b>Acc. to ISO 11452-4, 3. Ed. 2005 + updates 1 2009:</b> electricity feed-in up to 100 mA  <b>Acc. to ISO 11452-2, 2. Ed. 2004:</b> Freefield immunity with 100 V/m
Mechanical tests	<b>Acc. to ISO 16750-3:</b> Free fall
Chemical tests (at room temperature, brushing)	<b>Acc. to ISO ISO 16750-5:2010:</b> Battery fluid (22 h) Interior cleaner (2 h) Glass cleaner (2 h) Aceton (10 min) Ammoniumcontaining cleaner (22 h) Denatured alcohol (10 min) Transpiration (22 h) Cosmetic Products (Nivea Creme, 22 h) Refreshment containing coffein and sugar (Cola, 22 h) Cream, coffee whitener (22 h)

INPUT FEATURES - SUMMARY

<b>Pin 5, 8 (see A)</b>	Programmable as analog or digital input	
	Resolution	12 Bit
Voltage input 0...33 V (see A)	Input resistance	60 kΩ
	Input frequency <sup>1</sup>	$f_g = 69 \text{ Hz}$
	Accuracy	$\leq 3 \%$
Digital input (see B)	Input resistance	60 kΩ
	Input frequency <sup>1</sup>	$f_g = 69 \text{ Hz}$
	Turn-on threshold	$6.1 \pm 0.2 \text{ V}$
	Turn-off threshold	$4.0 \pm 0.2 \text{ V}$

<sup>1</sup> Cutoff frequency (-3 dB)

OUTPUT FEATURES - SUMMARY

<b>Pin 5,8 (optional)</b>	Protective circuit for inductive loads	Integrated
	Wire fault diagnostics	Possible via current sense
	Short circuit diagnostics	Possible via current sense
Digital, positive switching (high side; see C)	Switching voltage max. switching current (permanent, T = +85 °C)	9...32 V DC 1 A (DO)
	Conversion factor	1 Digit $\approx 2.4 \pm 0.2 \text{ mA}$ for currents >100 mA
	PWM output (high side; see C)	Switching voltage max. switching current (permanent, T = +85 °C)
	Conversion factor	1 Digit $\approx 2.4 \pm 0.2 \text{ mA}$ for currents >100 mA
Short circuit resistance against GND and U <sub>s</sub>	Switching-off is controlled by high side driver for <b>each output</b> channel	

<b>Pin 5, (optional)</b>	Protective circuit for inductive loads	Not integrated
	Wire fault diagnostics	-
	Short circuit diagnostics	-
	Short circuit resistance against GND and U <sub>s</sub>	Integrated
12 V Ref Output (see Description)	Switching voltage max. switching current (permanent, T = +85 °C)	15...32 V DC 80 mA at 28 V 100 mA at 24 V

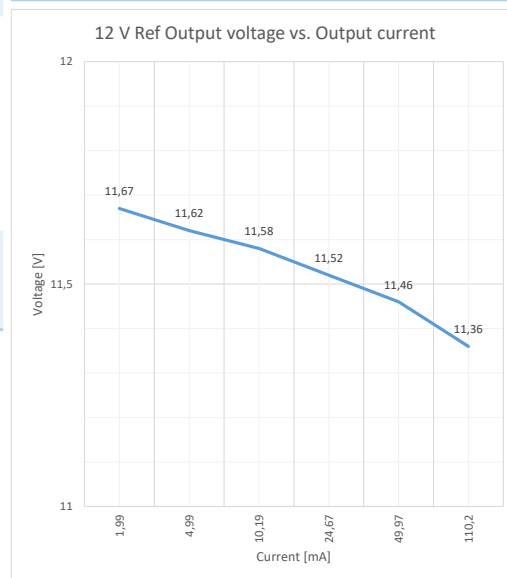

12 V Ref output with load  
(Voltage drop due to protective circuit)

PIN ASSIGNMENT POWER SUPPLY AND INTERFACES

Pin	Description	Pin	Description
2	Contact 30 / supply voltage, activation contact 30 measurement via MC_DO_EN_AI_KL30	1	CAN1-H
4	Contact 15 / Ignition	3	CAN1-L
6	Contact 31 / Ground	5	LIN0 (optional) / 12 V Ref (optional), max. output: see Page 2
		7	CAN0-H
		8	LIN1 (optional)
		9	CAN0-L

PIN ASSIGNMENT IN- AND OUTPUTS

Pin	Signal	Description	Pin	Signal	Description
5	AI_IO2	Analog input 2 0...33 V or	8	AI_IO1	Analog input 1 0...33 V or
	DI_AI_IO2	Digital input 2 or		DI_AI_IO1	Digital input 1 or
	DO_HSD2_OUT	Digital output 2 or		DO_HSD1_OUT	Digital output or
	PWM_HSD2_OUT	PWM output2 <sup>2</sup> or		PWM_HSD1_OUT	PWM output1 <sup>2</sup> or
	LIN <sup>3</sup>	LIN0 (optional) or		LIN <sup>3</sup>	LIN1 (optional for assembly variant)
	MC_DO_12V_	activation 12 V reference voltage			
	DCDC_EN	(optional)			

<sup>2</sup> initiated with f = 1 kHz and 0 % DC, DC selectable in 1 % steps (1000 = 100 %), see Applics Studio User API

<sup>3</sup> Numbering can be generated dynamically (LIN0 / LIN1) via ApplicsStudio (LDF interpreter).

LDF-INTERPRETER IN THE APPLICS STUDIO

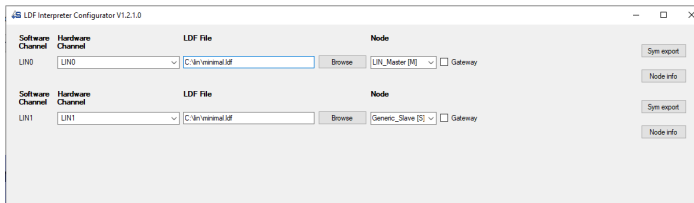

**Software Channel**

This automatically generated identifier is used to address the LIN bus in the software. It is used as a prefix for the data points, "schedule tables" etc. generated from the LDF (e.g. LIN0\_DP\_COMM\_ERROR, LIN0\_ST\_MAIN). The designation of the "LIN module" in the C code is formed by LIN\_BUS\_0 or LIN\_BUS\_1.

**Hardware Channel**

One of the available hardware channels can be assigned to the software channel on the left. The hardware channel corresponds to the printed pin designation on the housing.

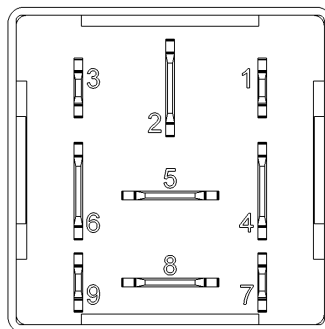

view of plug

PIN FEATURE MAP

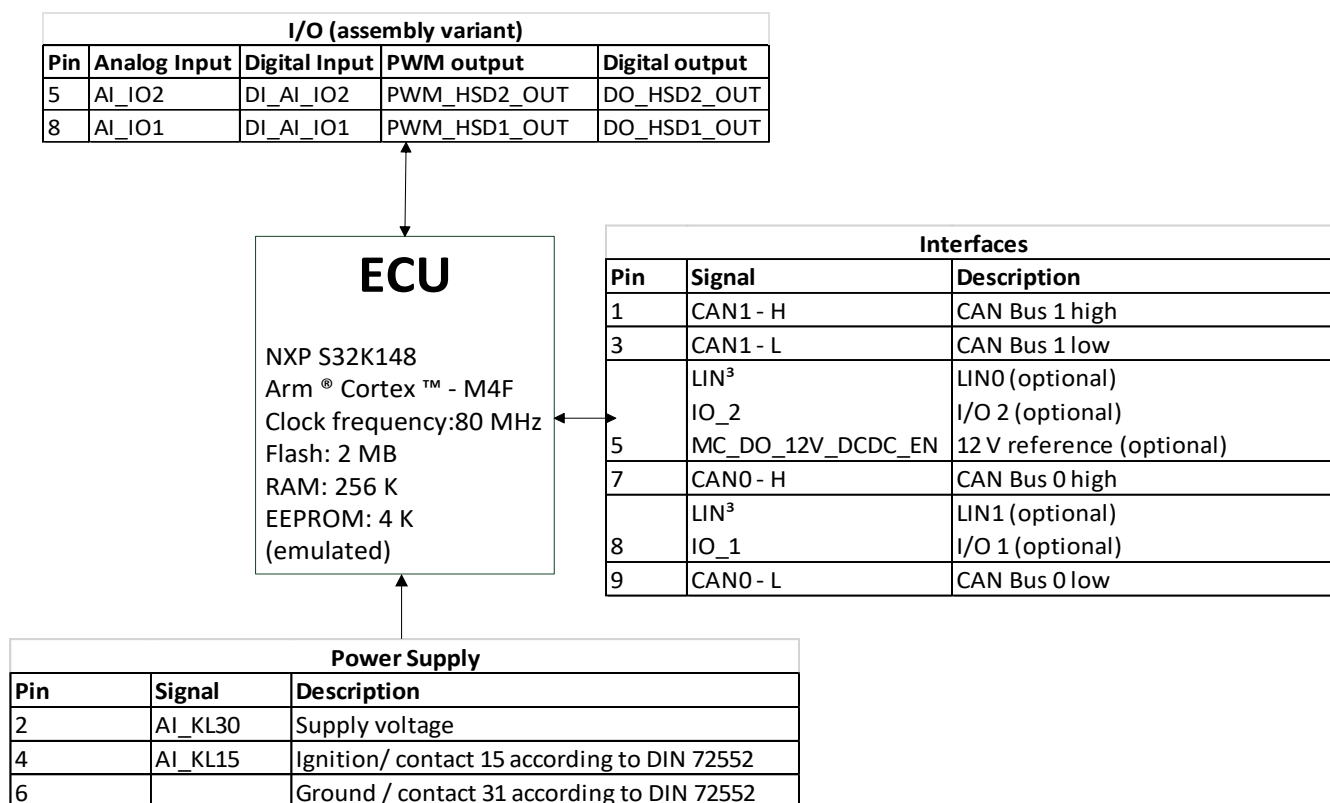

BLOCK FUNCTION DIAGRAM

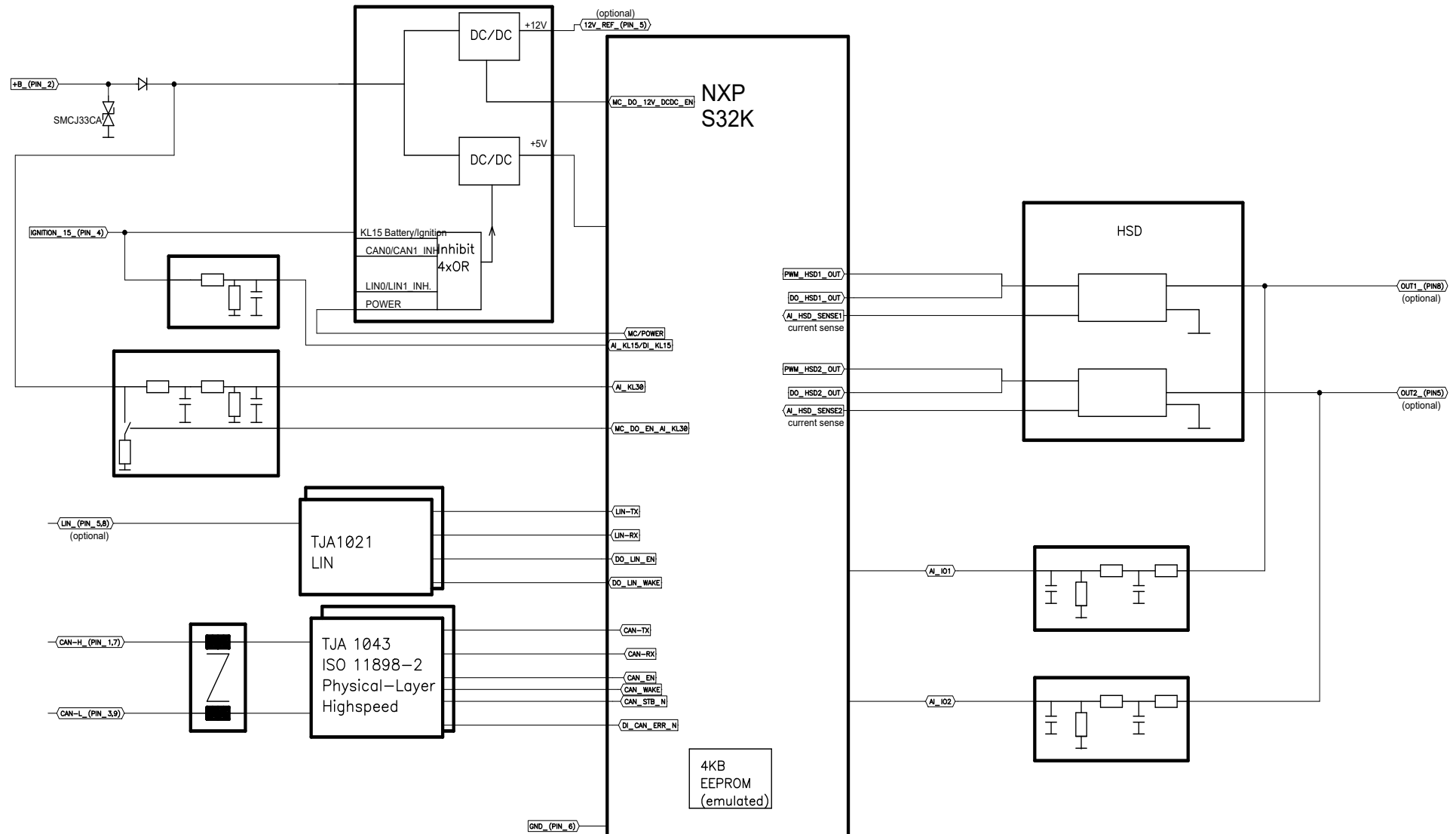

TECHNICAL DRAWING IN MM [INCH], TOLERANCES ACCORDING TO ISO 2768-1 V

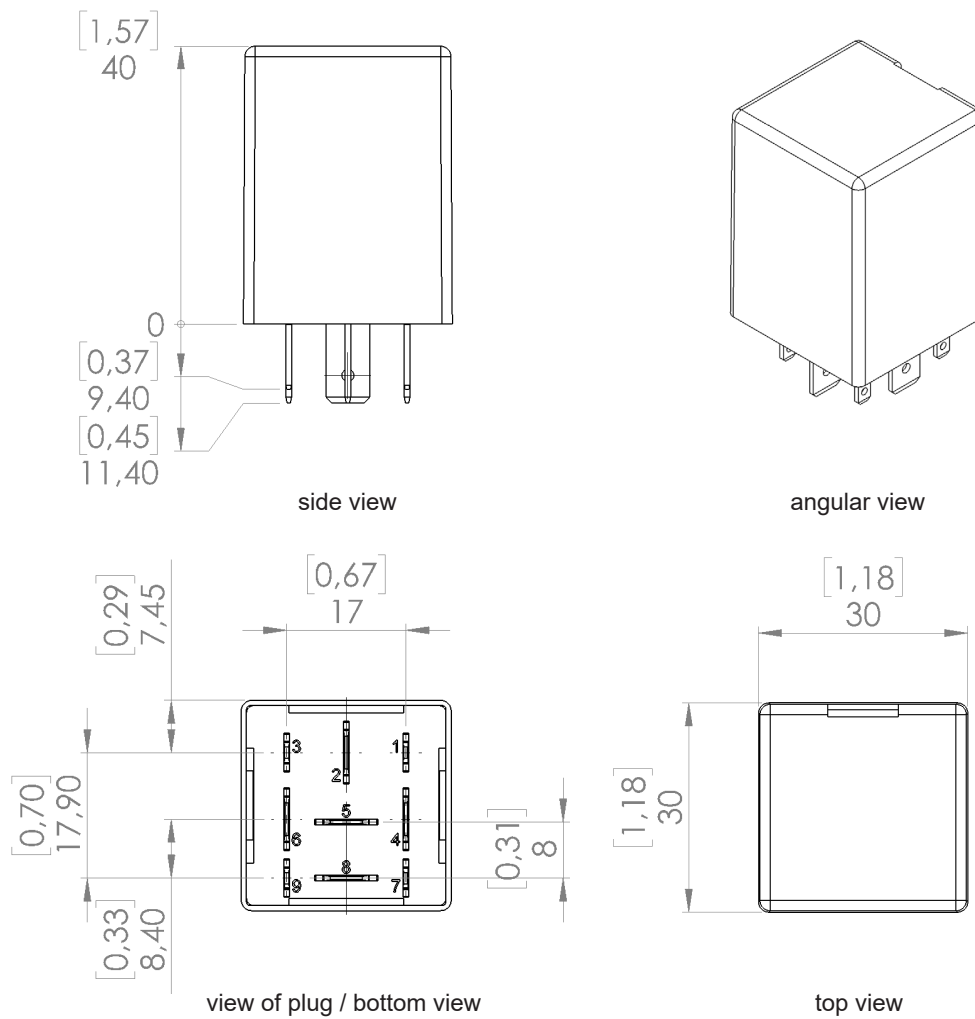

ASSEMBLY OPTIONS AND ORDER INFORMATION

	Inputs		Outputs	Wake Up source	CAN	Terminating resistor	LIN		Description
	A Voltage 0...33 V	B Digital input	C I/O's (can be used as analog or digital inputs or digital-/PWM output)		CAN 0/1	CAN 0/1	LIN1	LIN0	
<b>1.156.200.2600</b>				CAN, LIN1, KL15, DO_POWER	X		Master, 12 V		supply voltage range 15...32 V Activate LIN via 12V reference (MC_DO_12V_DCDC_EN)
<b>1.156.300.0000</b>				CAN, LIN0, LIN1, KL15, DO_POWER	X		Master, contact 30	Master, contact 30	supply voltage range 9...32 V
<b>1.156.200.2000</b>				CAN, LIN0, LIN1, KL15, DO_POWER	X		Master, 12 V	Master, contact 30	supply voltage range 15...32 V
<b>1.156.300.4000</b>	8	8	8	CAN, LIN0, KL15, DO_POWER	X			Master, contact 30	supply voltage range 9...32 V
<b>1.156.300.4400</b>	5,8	5,8	5,8	CAN, KL15, DO_POWER	X				supply voltage range 9...32 V
<b>1.156.300.5500</b>	5,8	5,8		CAN, KL15, DO_POWER	X				supply voltage range 9...32 V
<b>1.156.311.0000</b>				CAN, LIN0, LIN1, KL15, DO_POWER	X	120 Ω	Master, contact 30	Master, contact 30	supply voltage range 9...32 V
<b>1.156.311.5500</b>	5,8	5,8		CAN, KL15, DO_POWER	X	120 Ω			supply voltage range 9...32 V

SCIP NUMBERS

Assembly Variant	SCIP Number
1.156.200.2600	a61e4499-6c1f-43bf-8ecd-fc6367cddedc
1.156.300.0000	a61e4499-6c1f-43bf-8ecd-fc6367cddedc
1.156.200.2000	a61e4499-6c1f-43bf-8ecd-fc6367cddedc
1.156.300.4000	3e6e7f8f-4d37-4bb6-8aad-fd266979ff13
1.156.300.4400	c3331cba-fa44-4cf1-b0a4-cca8902a49ef
1.156.300.5500	a61e4499-6c1f-43bf-8ecd-fc6367cddedc
1.156.311.0000	a61e4499-6c1f-43bf-8ecd-fc6367cddedc
1.156.311.5500	a61e4499-6c1f-43bf-8ecd-fc6367cddedc

ACCESSORIES

Description	Order Number
Applics Studio Bundle	1.100.200.00
Socket package watertight 40 mm	1.017.010.40
Socket	1.017.002.00
FASTON terminal for latching 2.8 mm 0.5-1.0 mm <sup>2</sup>	105292
FASTON terminal for latching 6.3 mm 1 mm <sup>2</sup>	102355
PCAN-USB FD interface	503750



MANUFACTURER

MRS Electronic GmbH & Co. KG  
 Klaus-Gutsch-Str. 7  
 78628 Rottweil  
 Germany

NOTES ON WIRING AND CABLE ROUTING

PWM outputs may not be connected with each other or bypassed.

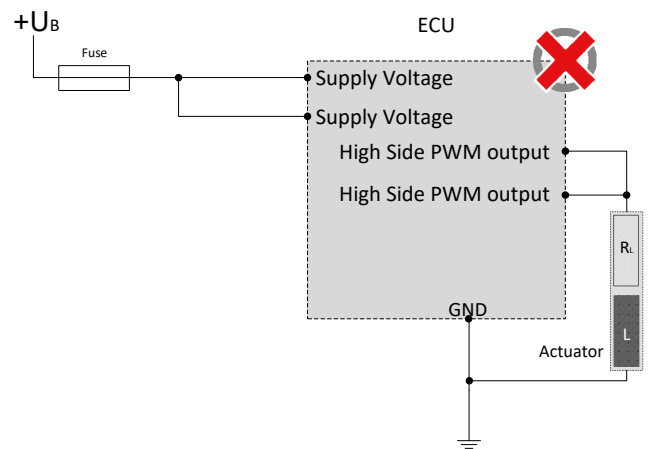
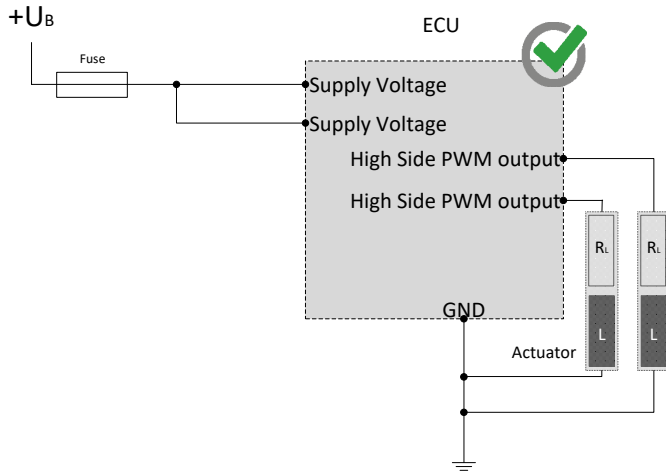

Hightside outputs may only be switched to ground.

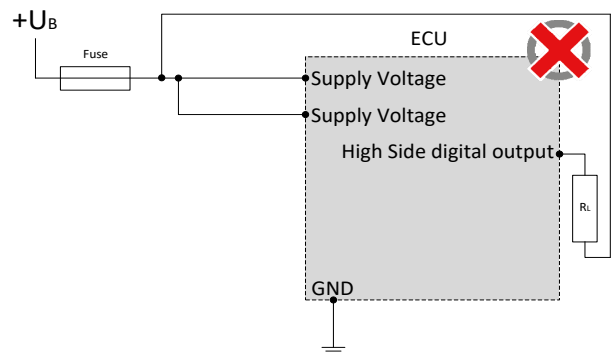
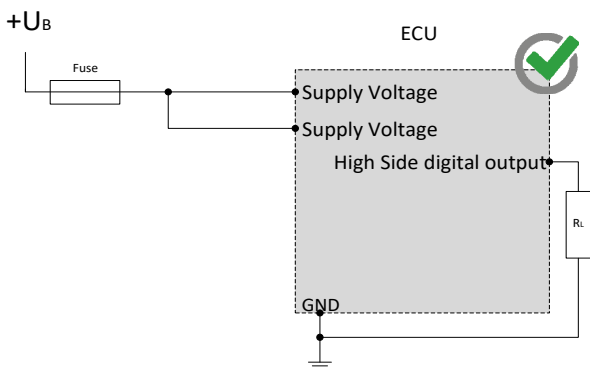
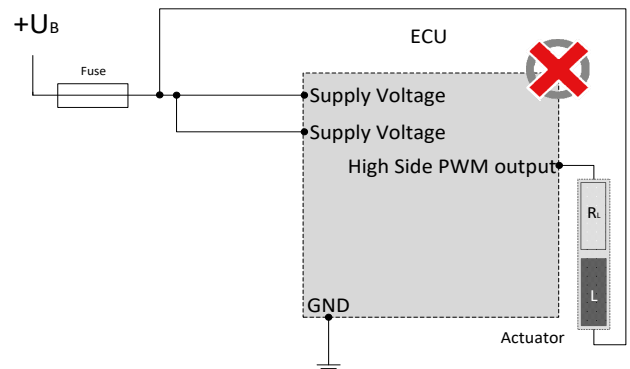
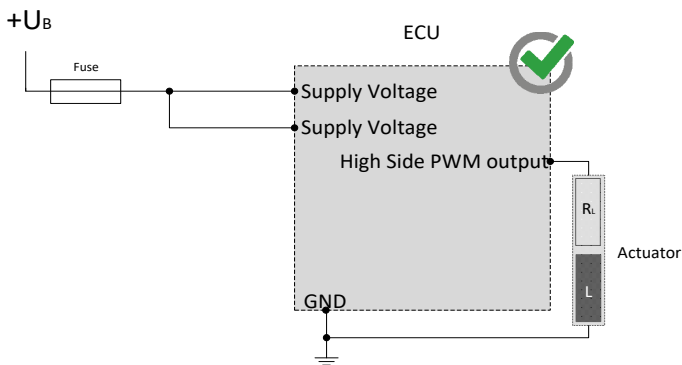

CAN / LIN bus communication is the main communication between the control unit and the vehicle. Therefore, connect the CAN / LIN bus with special care and check the correct communication with the vehicle to avoid undesired behavior.

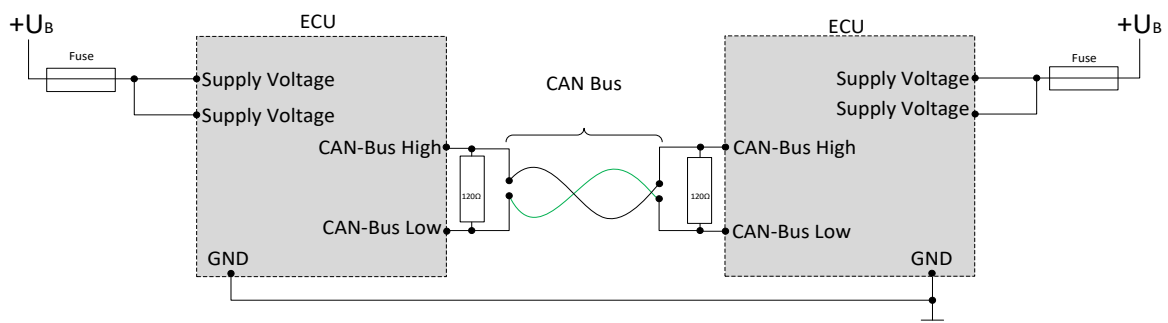

NOTES ON WIRING AND CABLE ROUTING

The control must be protected against overload (see performance data)

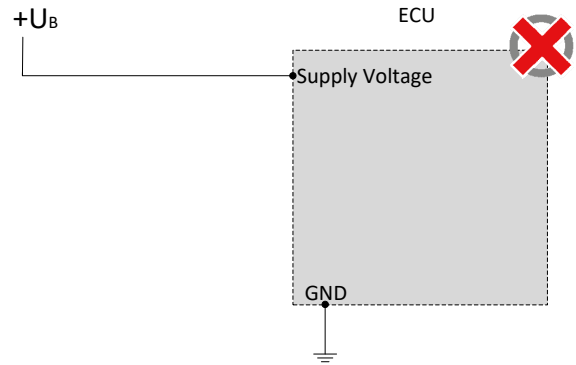
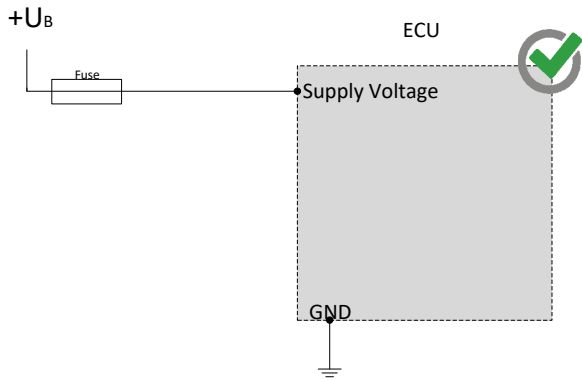

## SAFETY AND INSTALLATION INFORMATION

It is essential to read the instructions in full thoroughly before working with the device.

Please note and comply with the instructions in the operating instructions and the information in the device data sheet, see [www.mrs-electronic.com](http://www.mrs-electronic.com)

**Staff qualification:** Only staff with the appropriate qualifications may work on this device or in its proximity.

### SAFETY



**WARNING! Danger as a result of a malfunction of the entire system.**

Unforeseen reactions or malfunctions of the entire system may jeopardise the safety of people or the machine.

- Ensure that the device is equipped with the correct software and that the wiring and settings on the hardware are appropriate.



**WARNING! Danger as a result of unprotected moving components.**

Unforeseen dangers may occur from the entire system when putting the device into operation and maintaining it.

- Switch the entire system off before carrying out any work and prevent it from unintentionally switching back on.
- Before putting the device into operation, ensure that the entire system and parts of the system are safe.
- The device should never be connected or separated under load or voltage.



**CAUTION! Risk of burns from the housing.**

The temperature of the device housing may be elevated.

- Do not touch the housing and let all system components cool before working on the system.

### PROPER USE

The device is used to control or switch one or more electrical systems or sub-systems in motor vehicles and machines and may only be used for this purpose. The device may only be used in an industrial setting.



**WARNING! Danger caused by incorrect use.**

The device is only intended for use in motor vehicles and machines.

- Use in safety-related system parts for personal protection is not permitted.
- Do not use the device in areas where there is a risk of explosion.

**Correct use:**

- operating the device within the operating areas specified and approved in the associated data sheet.
- strict compliance with these instructions and no other actions which may jeopardise the safety of individuals or the functionality of the device.

**Obligations of the manufacturer of entire systems**

It is necessary to ensure that only functional devices are used. If devices fail or malfunction, they must be replaced immediately.

System developments, installation and the putting into operation of electrical systems may only be carried out by trained and experienced staff who are sufficiently familiar with the handling of the components used and the entire system.

It is necessary to ensure that the wiring and programming of the device does not lead to safety-related malfunctions of the entire system in the event of a failure or a malfunction. System behaviour of this type can lead to a danger to life or high levels of material damage.

The manufacturer of the entire system is responsible for the correct connection of the entire periphery (e.g. cable cross sections, correct selection/connection of sensors/actuators).

Opening the device, making changes to the device and carrying out repairs are all prohibited. Changes or repairs made to the cabling can lead to dangerous malfunctions. Repairs may only be carried out by MRS.

**Installation**

The installation location must be selected so the device is exposed to as low a mechanical and thermal load as possible. The device may not be exposed to any chemical loads.

Install the device in such a manner that the plugs point downwards. This means condensation can flow off the device. Single seals on the cables/leads must be used to ensure that no water gets into the device.

**Putting into operation**

The device may only be put into operation by qualified staff. This may only occur when the status of the entire system corresponds to the applicable guidelines and regulations.

## FAULT CORRECTION AND MAINTENANCE



**NOTE The device is maintenance-free and may not be opened.**

- If the device has damage to the housing, latches, seals or flat plugs, it must be taken out of operation.

Fault correction and cleaning work may only be carried out with the power turned off. Remove the device to correct faults and to clean it.

Check the integrity of the housing and all flat plugs, connections and pins for mechanical damage, damage caused by overheating, insulation damage and corrosion. In the event of faulty switching, check the software, switches and settings.

Do not clean the device with high pressure cleaners or steam jets. Do not use aggressive solvents or abrasive substances.