

mounting direction

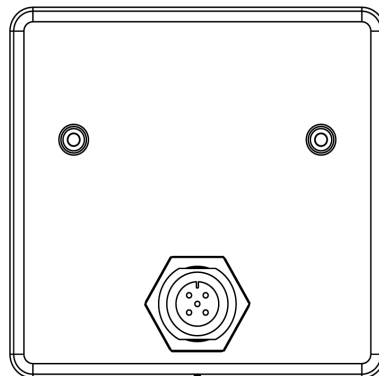

view of plug

DESCRIPTION

The MRS MConn Mini with its 2.4 inch colour display is the smallest of the MConn series. The product can be programmed according to your requirements, making it versatile and ideal for use as a display inside and outside the driver's cab. You can freely assign your desired functions to the 4 capacitive buttons.

TECHNICAL DATA

Housing	ABS housing black with PMMA front screen
Display	2.4" IPS Colour TFT Display 320x240 500 cd/m ² Viewing angle up to 80°
Weight	100 g
Temperature range (acc. to ISO 16750-4)	Operation: -20 to +60 °C Storage: -30 to +80 °C
Environmental protection acc. to ISO 20653	IP 6K8
Current consumption	86 mA at 12 V 53.9 mA at 24 V
Over-current protection	1 A
Total Inputs and outputs	-
Operating voltage	9-32 V acc. to ISO 16750-2: 12 V (Code C) 24 V (Code E)
Overvoltage protection	starting at ≈ 33 V
Quiescent current	26.06 µA at 12 V 27.02 µA at 24 V
Reverse polarity protection	Yes
CAN Interfaces	CAN Interface 2.0 A/B, ISO 11898-2, 11898-5, CAN-FD capable
Features	4 capacitive buttons (configurable, with LED- and acoustic feedback) Switchable backlight with ambient light sensor Acoustic signal

REGULATORY APPROVALS AND TESTING

E1 approval	06 9698
Elektrical tests	Acc. to ISO 16750 – 2 and -4: Short circuit protection Reverse polarity test Ground offset Interruption pin and plug Storage test at +80 °C and -30 °C Operation test at +60 °C and -20 °C Startpulse (former Pulse 4 acc. ISO 7637) Load Dump for 24 V (RI=7Ω) Acc. to ISO 7637 - 2: Pulse 1, 2a, 2b, 3a, 3b, degree of severity III Acc. to ISO 10605: ESD air discharge housing: ±4 kV ESD direct discharge housing/Pins: ±8 kV

PROGRAMMING

Programming system

MRS APPLICS STUDIO

The Applics Studio is the new development and toolplatform for our modules. Programm your MRS controller easy and fast with our independent software. Your application is of primary importance.

PIN ASSIGNMENT - POWER SUPPLY AND INTERFACES VARIANT WITH NMEA PLUG

Pin	Pin description	Pin	Pin description
1	optional: Lin Bus	3	Contact 31 / Ground
2	Contact 30 / operating voltage	4	CAN high
		5	CAN low

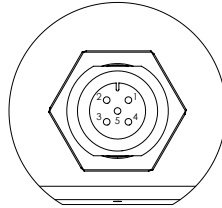

Pin numbering NMEA plug

TECHNICAL DRAWING VARIANT NMEA-PLUG IN MM [INCH]

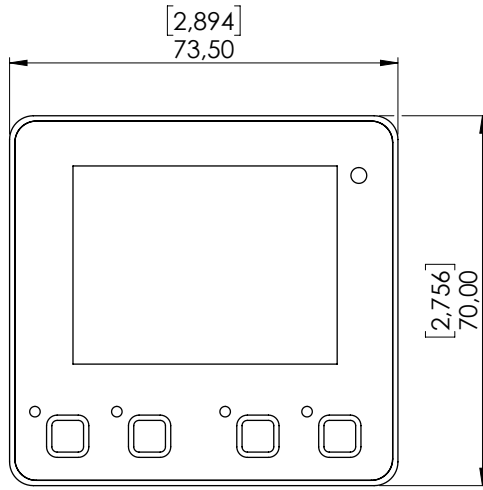

front view

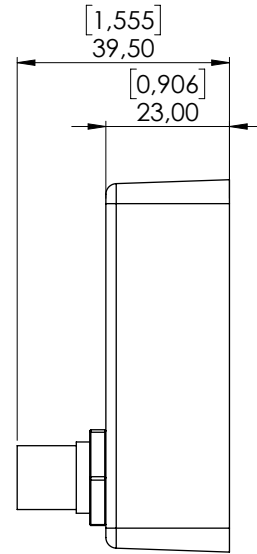

side view

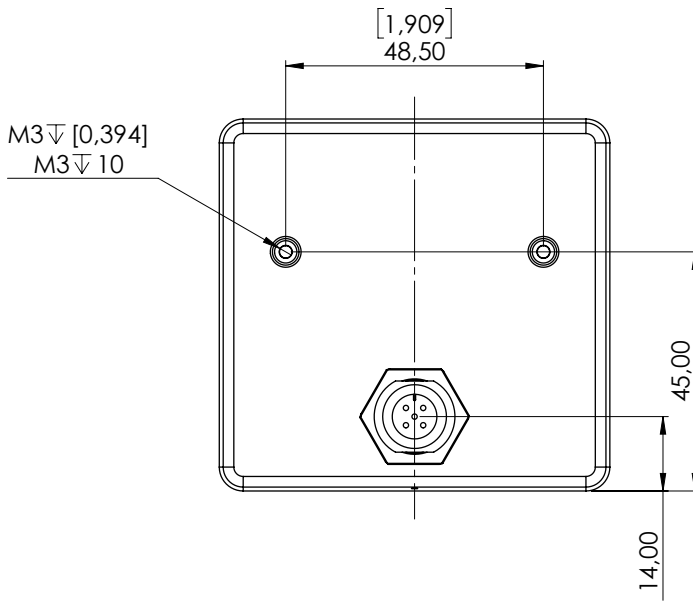

rear view

ASSEMBLY VARIANTS AND ORDERING INFORMATION

	CAN Bus features		Serial Port /Interface		mechanical properties		electrical properties	
	High-Speed	Terminating resistor	RS485	LIN	Environmental protection	Plug-/Connector-form	Flash-storage	Wake-up possibility
1.157.300.0100	X	-	-	-	IP 6K8	NMEA-plug	int. S32K144	CAN Bus
1.157.302.0120	X	-	-	Master or Slave selectable	IP 6K8	NMEA plug	int. S32K144	CAN Bus LIN Bus

ACCESSORIES

Description	Order number
Applics Studio Bundle	1.100.200.00
Cable harness Mini Display for programming	503838
PCAN-USB Interface	105358
Connector Kit NMEA 2000	302392

BRACKETS FROM OTHER MANUFACTURERS

Name	Manufacturer No.	Link
RAM Mounts AMPS Halterset	RAM-B-138U	https://www.mount-shop.de/AMPS-Halterset-mit-Diamond-Base-und-Round-Base/RAM-B-138U
RAM Mounts Diamond Base	RAM-B-238U	https://www.mount-shop.de/Diamond-Base/RAM-B-238U
RAM Mounts Socket Arm Standard	RAM-B-201U	https://www.mount-shop.de/Socket-Arm-Standard-9-47-cm-3-73-inch/RAM-B-201U
RAM Mounts Round Base	RAM-B-202U	https://www.mount-shop.de/Round-Base/RAM-B-202U



MANUFACTURER

MRS Electronic GmbH & Co. KG
 Klaus-Gutsch-Str. 7
 78628 Rottweil
 Germany

SAFETY AND INSTALLATION INFORMATION

It is essential to read the instructions in full thoroughly before working with the device.

Please note and comply with the instructions in the operating instructions and the information in the device data sheet, see www.mrs-electronic.de

Staff qualification: Only staff with the appropriate qualifications may work on this device or in its proximity.

SAFETY

- ⚠ WARNING! Danger as a result of a malfunction of the entire system.**
Unforeseen reactions or malfunctions of the entire system may jeopardise the safety of people or the machine.
- Ensure that the device is equipped with the correct software and that the wiring and settings on the hardware are appropriate.

- ⚠ WARNING! Danger as a result of unprotected moving components.**
Unforeseen dangers may occur from the entire system when putting the device into operation and maintaining it.
- Switch the entire system off before carrying out any work and prevent it from unintentionally switching back on.
 - Before putting the device into operation, ensure that the entire system and parts of the system are safe.
 - The device should never be connected or separated under load or voltage.

- ⚠ CAUTION! Risk of burns from the housing.**
The temperature of the device housing may be elevated.
- Do not touch the housing and let all system components cool before working on the system.

PROPER USE

The device is used to control or switch one or more electrical systems or sub-systems in motor vehicles and machines and may only be used for this purpose. The device may only be used in an industrial setting.

- ⚠ WARNING! Danger caused by incorrect use.**
The device is only intended for use in motor vehicles and machines.
- Use in safety-related system parts for personal protection is not permitted.
 - Do not use the device in areas where there is a risk of explosion.

Correct use:

- operating the device within the operating areas specified and approved in the associated data sheet.
- strict compliance with these instructions and no other actions which may jeopardise the safety of individuals or the functionality of the device.

Obligations of the manufacturer of entire systems

It is necessary to ensure that only functional devices are used. If devices fail or malfunction, they must be replaced immediately.

System developments, installation and the putting into operation of electrical systems may only be carried out by trained and experienced staff who are sufficiently familiar with the handling of the components used and the entire system.

It is necessary to ensure that the wiring and programming of the device does not lead to safety-related malfunctions of the entire system in the event of a failure or a malfunction. System behaviour of this type can lead to a danger to life or high levels of material damage.

The manufacturer of the entire system is responsible for the correct connection of the entire periphery (e.g. cable cross sections, correct selection/connection of sensors/actuators).

Opening the device, making changes to the device and carrying out repairs are all prohibited. Changes or repairs made to the cabling can lead to dangerous malfunctions. Repairs may only be carried out by MRS.

Installation

The installation location must be selected so the device is exposed to as low a mechanical and thermal load as possible. The device may not be exposed to any chemical loads.

Install the device in such a manner that the plugs point downwards. This means condensation can flow off the device. Single seals on the cables/leads must be used to ensure that no water gets into the device.

Putting into operation

The device may only be put into operation by qualified staff. This may only occur when the status of the entire system corresponds to the applicable guidelines and regulations.

FAULT CORRECTION AND MAINTENANCE

- i NOTE The device is maintenance-free and may not be opened.**
- If the device has damage to the housing, latches, seals or flat plugs, it must be taken out of operation.

Fault correction and cleaning work may only be carried out with the power turned off. Remove the device to correct faults and to clean it.

Check the integrity of the housing and all flat plugs, connections and pins for mechanical damage, damage caused by overheating, insulation damage and corrosion. In the event of faulty switching, check the software, switches and settings.

Do not clean the device with high pressure cleaners or steam jets. Do not use aggressive solvents or abrasive substances.

NOTES ON WIRING AND CABLE ROUTING

The controller has to be secured in accordance to the overload. (view performance data)

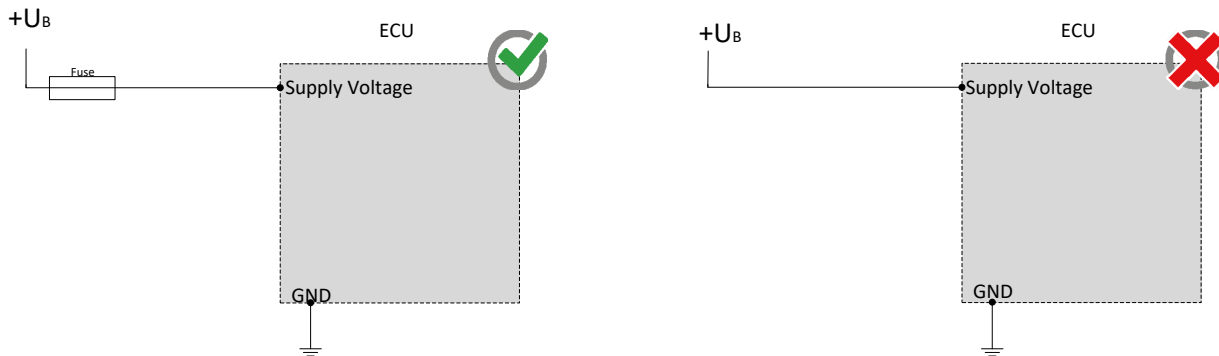

CAN bus communication is the main communication between the control unit and the vehicle. Therefore, connect the CAN bus with special care and check the correct communication with the vehicle to avoid undesired behavior.

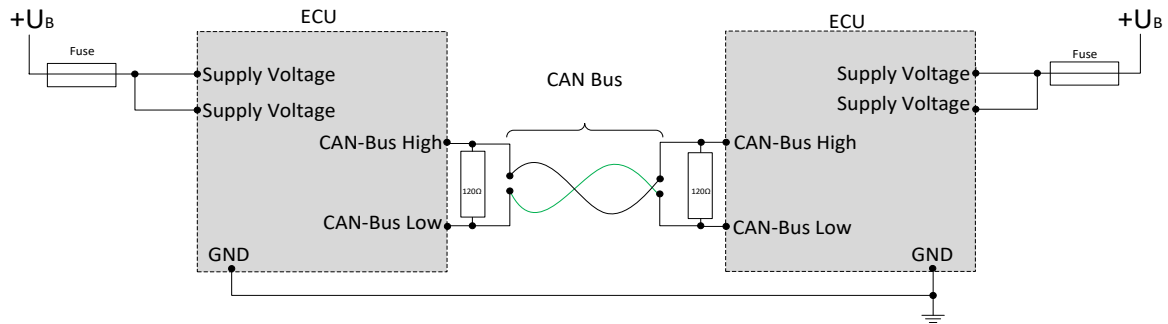

WARNING

The hole at the bottom of the housing is for the membrane. To avoid damaging the membrane, do not insert any sharp objects into the hole!