

DESCRIPTION

The versatile M3600 is both controller and gateway. With the up to 39 inputs and outputs, you have many options to control various components.

TECHNICAL DATA

Housing	Aluminum casing with cooling fins
Connector	Tyco AMPMODU WP 121 pins
Housing dimensions	95.1 x 179 x 39.3 mm (housing) 110.4 x 179 x 39.3 mm (incl. plug)
Weight	480 g
Temperature range acc. to ISO 16750-4	-40 °C...+85 °C
Environmental protection acc. to ISO 20653	IP68 when using the covers in the connector kit and the cable harness sheath acc. to the accessories list CAUTION! Follow the mechanical instructions!
Current consumption	67 mA
Over-current protection	40 A (see page 3)
Total inputs and outputs	38 (18 inputs; 10 I/O's; 10 outputs, 4 are PWM capable with integrated current measurement INA)
Inputs	Configurable as: Digital, positive encoder signals Analog (0...11.4 / 33.68 V) Digital, negative encoder signals Frequency inputs
Outputs	Configurable as: Digital, positive switching (High-Side) Depends on the equipment: PWM output up to 500 Hz Constant voltage source 5 V Const. current source max. 200mA
Supply voltage	9...32 V 12 V (Code B) and 24 V (Code E), acc. to ISO 16750-2
Overvoltage protection	≥ 33 V
Quiescent current	3.35 mA (24 V); 0.3 mA (12 V)
Reverse polarity protect.	yes
CAN Interfaces	CAN Interface 2.0 A/B, ISO 11898 compliant

REGULATORY APPROVALS AND TESTING

E1 Label	ECE-R10 Rev. 5
E1 type approval	10 R - 06 8037
Electrical tests	According to ISO 16750-2 or -4: Reverse polarity Disconnection pin/connector Superimposed alternating voltage Slow decrease and increase of supply voltage Momentary drop in supply voltage Reset behaviour at voltage drop Load test at T _{max} at +85 °C Long term overvoltage at T _{max} -20 °C Operation/storage test at T _{min} Operation/storage test at T _{max}
	According to ISO 7637-2: Pulse 1, 2a, 2b, 3a, 3b, 4

SOFTWARE/PROGRAMMING

Programming System
MRS APPLICS STUDIO
The Applics Studio is the new development and tool platform for our assemblies. Program your MRS controls quickly and easily with our stand-alone software. The focus is on your application.

INPUT FEATURES - SUMMARY

Pin 6, 7, 102, 106	Analog inputs 0...33 V Resolution	12 Bit	Pin 21, 23, 24	Analog inputs 0...33 V Resolution	12 Bit
Voltage input 0...33 V (see A)	Input resistance Input frequency Accuracy	$22.3 \pm 0.3 \text{ k}\Omega$ $f_g^* = 6 \text{ Hz}$ $\pm 5 \%$	Voltage input 0...33 V (see E)	Input resistance Input frequency Accuracy	$22.3 \pm 0.3 \text{ k}\Omega$ $f_g^* = 6 \text{ Hz}$ $\pm 5 \%$
Pin 8	Analog inputs or frequency inputs Resolution	12 Bit	Digital input Posi- tive (see E)	Input resistance Input frequency Turn-on threshold Turn-off threshold	$22.3 \pm 0.3 \text{ k}\Omega$ $f_g^* = 6 \text{ Hz}$ Pin 21 = 19.4 V Pin 23 = 21 V Pin 24 = 13.5 V Pin 21 = 19.2 V Pin 23 = 21 V Pin 24 = 13.5 V
Voltage input 0...11.3 V (see B)	Input resistance Input frequency Accuracy	$22 \pm 1 \text{ k}\Omega$ $f_g^* = 6 \text{ Hz}$ $\pm 3 \%$	Pin 56, 58, 60, 62, 75, 77, 79, 81	IOs (analog- or digital input) Resolution	12 Bit
Frequency input (via use of the digital input, programming via usercode.c see B)	Input resistance Accuracy Factor	$22 \pm 1 \text{ k}\Omega$ to 3.2 kHz $\pm 3 \%$ (measu- red with square wave signal with 10VPeak) Frequency = 4 x digits	Voltage input 0...11.3 V (see E)	Input resistance Input frequency Accuracy	15 k Ω $f_g^* = 6 \text{ Hz}$ $\pm 5 \%$
Pin 9	Analog inputs 0...11.3 V Resolution	12 Bit	Digital input Positive (see E)	Input resistance Input frequency Turn-on threshold Turn-off threshold	16.5 k Ω $f_g^* = 6 \text{ Hz}$ 7 V 7 V
Voltage input 0...11.3 V (see C)	Input resistance Input frequency Accuracy	$22 \pm 1 \text{ k}\Omega$ $f_g^* = 6 \text{ Hz}$ $\pm 3 \%$	Pin 116, 121	IOs (Analog inputs 0...11.3 V) Resolution	12 Bit
Pin 13, 14, 32, 33	PT200/PT1000 Sen- sor Input Resolution	12 Bit	Digital input 0...11.3 V(see E)	Input resistance Input frequency Accuracy	$22 \pm 1 \text{ k}\Omega$ $f_g^* = 6 \text{ Hz}$ $\pm 3 \%$
Pull-up Input (see D)	Pull-up resistance Input frequency	1 k Ω $f_g^* = 6 \text{ Hz}$	Pin 108	Input for inductive ro- tary encoder sensors Resolution	12 Bit
Pin 19, 38, 40, 42, 43	Analog- or digital input Resolution	12 Bit	Voltage input 0...5 V (see B) Max. Amplitude 6.5 V	Accuracy	$\pm 3 \%$ up to 200 Hz
Voltage input 0...11.3 V (see E)	Input resistance Input frequency Accuracy	$22.3 \pm 0,3 \text{ k}\Omega$ $f_g^* = 6 \text{ Hz}$ $\pm 3 \%$ max.	* f_g = cutoff frequency (-3 dB amplitude) when using the analog input		
Digital input Positive (see E)	Input resistance Input frequency Turn-on threshold Turn-off threshold	$22,6 \pm 0,2 \text{ k}\Omega$ $f_g^* = 6 \text{ Hz}$ 7 V 7 V			

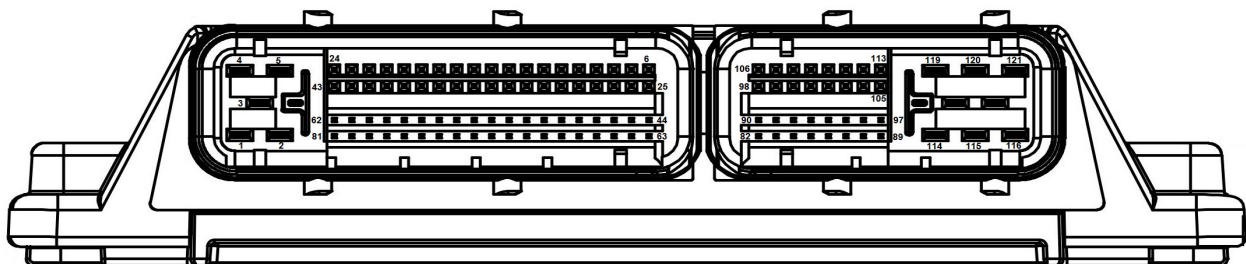

OUTPUT FEATURES - SUMMARY

Pin 48, 50, 52, 54, 56, 58, 60, 62, 75, 77, 79, 81 (VNQ5050)	Protective circuit for inductive loads	Optionally integrated	Pin 44, 111 (internally bridged)	Wire fault diagnostics	Possible via current sense
	Wire fault diagnostics	Possible via current sense		Short circuit diagnostics	Possible via current sense
	Short circuit diagnostics	Possible via current sense		Short circuit resistance against GND and V_s	Yes, acc. to ISO 16750-2:2012
Digital, positive switching (high side; see F and G)	Switching voltage Switching current Conversion factor current sense	9...32 V DC 0.02...2.5 A** 1 Digit 0.9 ± 0.1 mA	Digital output (see I)	Connection possibility for external Panel up to max. 200 mA in total**	
Short circuit protection against GND and U_B	Internal overtemperature protection, latch-off can be realized by software application		Pin 114 (BTS650)	Wire fault diagnostics	Possible via current sense
Pin 67, 69, 71, 73 (VNQ5050 with PWM and INA current sense)	Protective circuit for inductive loads	Optionally integrated	Digital, positive switching (High-Side; see H)	Short circuit diagnostics	Possible via current sense
	Wire fault diagnostics	Possible via current sense		Switching voltage Switching current Conversion factor current sense	9...32 V DC 0.02...10 A** 1 Digit 0.9 ± 0.1 mA
	Short circuit diagnostics	Possible via current sense		Short circuit protection against GND and U_B	
Digital, positive switching (high side; see H)	Switching voltage Switching current Conversion factor current sense	9...32 V DC 0.02...2.5 A** 1 Digit 0.9 ± 0.1 mA	Pin 116, 121 (BTS6143)	Wire fault diagnostics	Possible via current sense
PWM output (see H)	Output frequency Duty cycle Resolution Switching current	500 Hz 0...100 % 1 ‰ Up to 2.5A** (see page 5)	Digital, positive switching (high side; see E)	Short circuit diagnostics	Possible via current sense
Short circuit protection against GND and U_B	Internal overtemperature protection, latch-off can be realized by software application		Short circuit protection against GND and U_B	Switching voltage Switching current Conversion factor current sense	9-32 V DC 0.02-10 A** 1 Digit 1.2 ± 0.1 mA
				Switching-off is controlled by high side driver (latch-off)	

****ATTENTION:** The maximum current load capacity of the total module amounts 40 A, if the terminals 30_1 (pin 119) and 30_2 (pin 120) are connected.

PIN ASSIGNMENT POWER SUPPLY AND INTERFACES

Pin	Description	Pin	Description
15	CAN2-H	105	Battery/ignition contact KL 15 GSM, optional as DI
16, 17, 18	RS 485 B	113	Battery/ignition contact KL 15, optional as DI
20	CAN1-L	119	KL 30_1: supply voltage for outputs and supply voltage for CPU
22	CAN0-H	120	KL 30_2: supply voltage for outputs and supply voltage for CPU
27	5V sensor output	1, 3, 4, 10, 11, 12, 28, 29, 30, 31, 45, 46, 47, 49, 51, 53, 55, 57, 59, 61, 63, 64, 65, 66, 68, 70, 72, 74, 76, 78, 80, 82, 83, 84, 85, 86, 89, 90, 91, 92, 93, 94, 97, 99, 100, 101, 103, 115, 117, 118	Ground
34	CAN2-L		
35, 36, 37	RS 485 A		
39	CAN1-H		
41	CAN0-L		
98	5V sensor output		

PIN ASSIGNMENT INPUTS AND OUTPUTS

Alternative functions like frequency/current or pull-up inputs are depending on assembly options (see table on page 5).

Pin	Signal	Description	Pin	Signal	Description
6	AIM_30V_X6	Analog input 0...33 V	62	AIM_IO1 DIM_IO1 DOM_IO1 AIM_CUR_IO1	Analog input IO1 0...11.4 V or digital input or digital output with current sense
7	AIM_30V_X7	Analog input 0...33V	67	DO_PWM_O8 PWM_O8 AI_SENS_PWM_O8	Digital output DO8 with PWM capability and INA current sense
8	AIM_RPM DI_RPM 0	Frequency input Digital input 0...11.3 V	69	DO_PWM_O7 PWM_O7 AI_SENS_PWM_O7	Digital output DO7 with PWM capability and INA current sense
9	AIM_INPUT1	Analog input 0...11.3 V	71	DO_PWM_O6 PWM_O6 AI_SENS_PWM_O6	Digital output DO6 with PWM capability and INA current sense
13	AIM_PT200_1P	Pull-up input PT200/PT1000	73	DO_PWM_O5 PWM_O5 AI_SENS_PWM_O5	Digital output DO5 with PWM capability and INA current sense
14	AIM_PT200_2P	Pull-up input PT200/PT1000	75	AIM_IO8 DIM_IO8 DOM_IO8 AIM_CUR_IO8	Analog input IO8 0...11.4 V or digital input or digital output with current sense
19	AIM_I4 DIM_I4	Analog input 0...11.3 V or digital input 0...11.3 V	77	AIM_IO7 DIM_IO7 DOM_IO7 AIM_CUR_IO7	Analog input IO7 0...11.4 V or digital input or digital output with current sense
21	AIM_I3 DIM_I3	Analog input 0...33 V or digital input	79	AIM_IO6 DIM_IO6 DOM_IO6 AIM_CUR_IO6	Analog input IO6 0...11.4 V or digital input or digital output with current sense
23	AIM_I2 DIM_I2	Analog input 0...33 V or digital input	81	AIM_IO5 DIM_IO5 DOM_IO5 AIM_CUR_IO5	Analog input IO5 0...11.4 V or digital input or digital output with current sense
24	AIM_I1 DIM_I1	Analog input 0...33 V or digital input	102	AIM_30V_X102	Analog input 0...33 V
32	AIM_PT200_4P	Pull-up input PT200/PT1000	106	AIM_30V_X106	Analog input 0...33 V
33	AIM_PT200_3P	Pull-up input PT200/PT1000	108	DI_RPM_2	Input for inductive rotary encoders
38	AIM_I8 DIM_I8	Analog input 0...11.3 V or digital input 0...11.3 V	111	DOM_PANEL_ON AI_VCC_PANEL	Digital output VB Panel with max. 200 mA Analog input 0...13.7 V
40	AIM_I7 DIM_I7	Analog input 0...11.3 V or digital input 0...11.3 V	114	DO_NOX AI_NOX	Digital output NOX with current sense
42	AIM_I6 DIM_I6	Analog input 0...11.3 V or digital input 0...11.3 V	116	AI_OUT_CB_1 DOM_OUT_CB_1 AI_CUR_CB_1	Analog input 0...11.3 V or digital output CB1 with current sense
43	AIM_I5 DIM_I5	Analog input 0...11.3 V or digital input 0...11.3 V	121	AI_OUT_CB_2 DOM_OUT_CB_2 AI_CUR_CB_2	Analog input 0...11.3 V or digital output CB1 with current sense
44	DOM_PANEL_ON AI_VCC_PANEL	bridged to Pin 111			
48	DOM_O1 AIM_CUR_O1	Digital output O1 with current sense			
50	DOM_O2 AIM_CUR_O2	Digital output O2 with current sense			
52	DOM_O3 AIM_CUR_O3	Digital output O3 with current sense			
54	DOM_O4 AIM_CUR_O4	Digital output O4 with current sense			
56	AIM_IO3 DIM_IO3 DOM_IO3 AIM_CUR_IO3	Analog input IO3 0...11.4 V or digital input or digital output with current sense			
58	AIM_IO4 DIM_IO4 DOM_IO4 AIM_CUR_IO4	Analog input IO4 0...11.4 V or digital input or digital output with current sense			
60	AIM_IO2 DIM_IO2 DOM_IO2 AIM_CUR_IO2	Analog input IO2 0...11.4 V or digital input or digital output with current sense			

PIN - FEATURE MAP

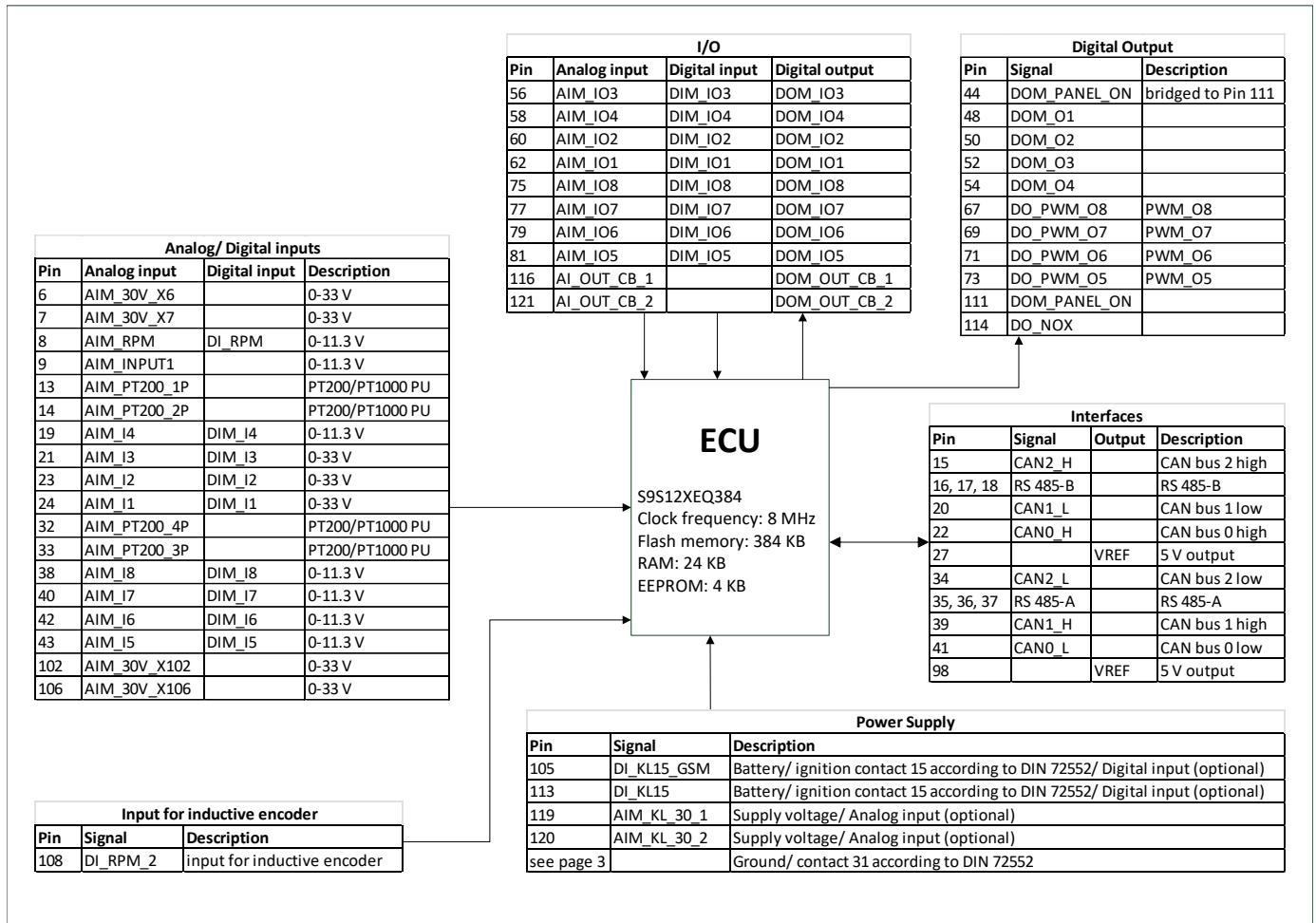

PINS - WITHOUT EXTERNAL CONNECTION

Pins

2, 5, 25, 26, 87, 88, 95, 96, 104, 107, 109, 110, 112

PERFORMANCE TESTS HIGH-SIDE-DRIVER OUTPUTS (MAXIMUM RATINGS)

Test without PWM (max. 2 channels per high side driver)
T = 85 °C

Load	Switched Outputs	Endurance [min]
4 x 4 A	O1-O8; IO1-IO8	5
2 x 5 A	O7, IO7	continuous
15 A	IO_CB1	continuous
15 A	IO_CB2	5
22 A	NOX_B_P	5
4 x 3 A	O1,O2,O3,O4	continuous

Test with PWM (max. 2 channels per high side driver)
T = 85 °C
PWM (200Hz, Duty cycle 90%)

Load	Switched Outputs	Endurance [min]
5 A	O8	continuous
4 x 2.5 A	O5,O6,O7,O8	continuous
4 x 3 A	O5,O6,O7,O8	5

BLOCK FUNCTION DIAGRAM

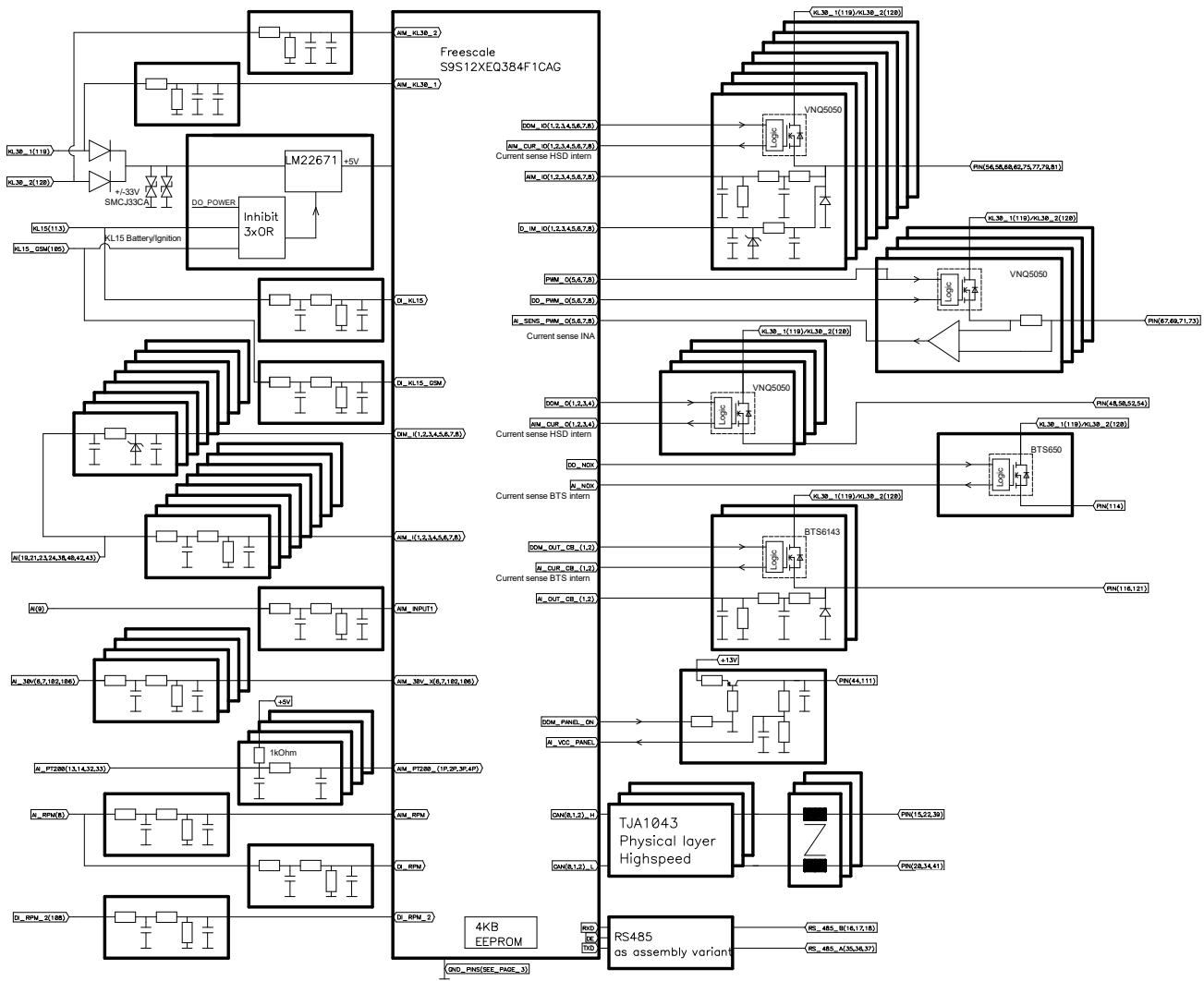

TECHNICAL DRAWING IN MM, TOLERANCES ACCORDING TO ISO 2768-1 V

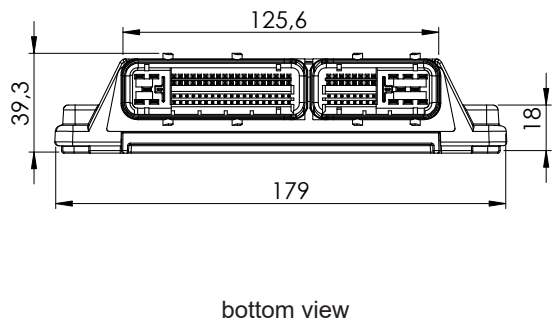
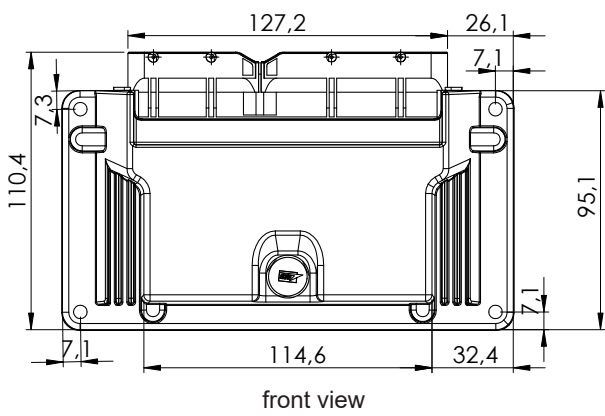

ASSEMBLY OPTIONS AND ORDER INFORMATION

Order number	Inputs						Outputs			CAN bus		Serial interface	DC/DC
	A Voltage 0...33 V	B Voltage or frequency	C Voltage 0...11.3V	D Pull up 1kΩ	E Voltage or digital	F I/O's (optionally as Analog-/digital input or digital output)	G Digital output	H Digital output or PWM ≤ 500 Hz	I Power supply ext. panel	High-Speed	CAN open		
1.300.300.00	6, 7, 102, 106	8	9, 108	13, 14, 32, 33	19, 21, 23, 24, 38, 40, 42, 43	56, 58, 60, 62, 75, 77, 79, 81, 116, 121	48, 50, 52, 54, 114	67, 69, 71, 73	44, 111	X		RS485	5 Volt Ref. 27, 98
1.300P.300.00	6, 7, 102, 106	8	9, 108	13, 14, 32, 33	19, 21, 23, 24, 38, 40, 42, 43	56, 58, 60, 62, 75, 77, 79, 81, 116, 121	48, 50, 52, 54, 114	67, 69, 71, 73	44, 111		X	RS485	27, 98

Variant	SCIP number
1.300.300.00	538a9f67-d2d0-499f-8299-c698eaad6a87
1.300P.300.00	4c2b4785-2daa-4cfc-b438-c91781920e8f

ACCESSORIES

Description	Order number
Programming tool MRS Applies Studio	1.100.200.01
Connector package M3600	114159
Crimp terminals Timer Junior 1.50 – 2.50 mm ²	107665
Single seal Junior Power Timer 1.5 mm ²	107304
Crimp terminal MQS 0.50 – 0.75 mm ²	109949
PCAN-USB Interface	105358
Cable set M3600 for programming	501246
Cavity Plug package for M3600 CAN PLC	300972
Cable harness sheath	Available from independent retailers



MANUFACTURER

MRS Electronic GmbH & Co. KG
 Klaus-Gutsch-Str. 7
 78628 Rottweil
 Germany

WIRING AND CABLE ROUTING RECOMMENDATIONS

The electronic system and the power outputs of a control unit must be supplied by the same power supply system.

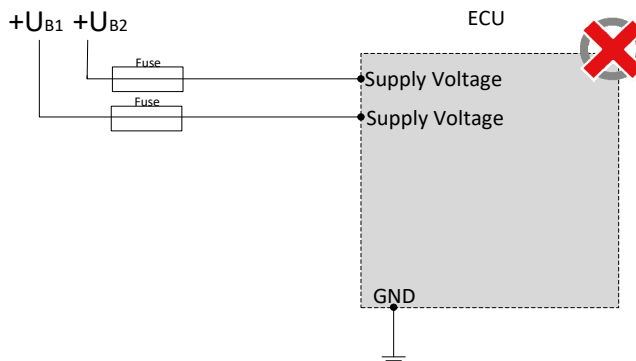
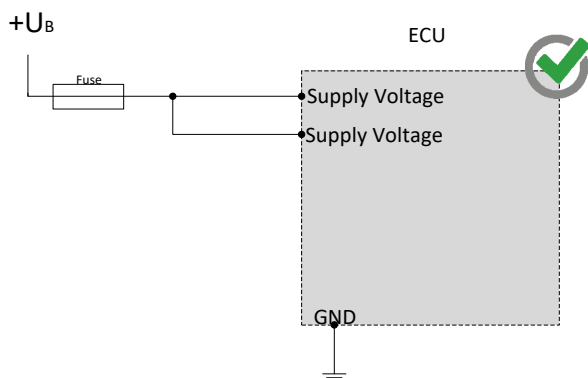

PWM outputs may not be connected with each other or bypassed.

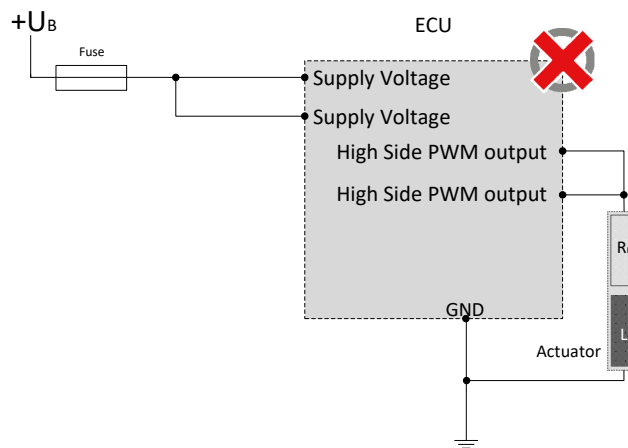
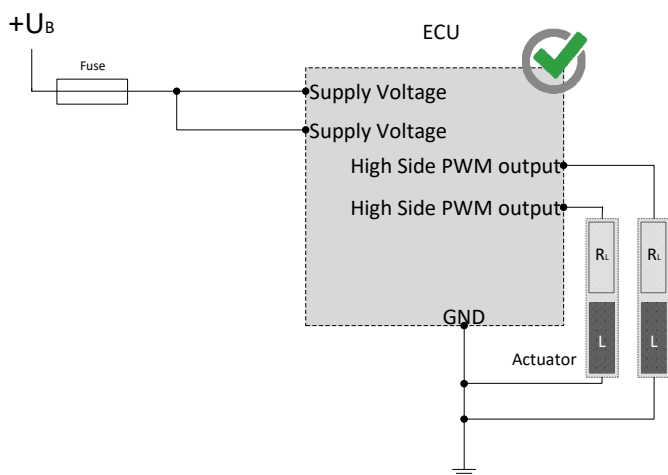

The pins (I/Os) can be used in combination and may not be switched externally against supply voltage.

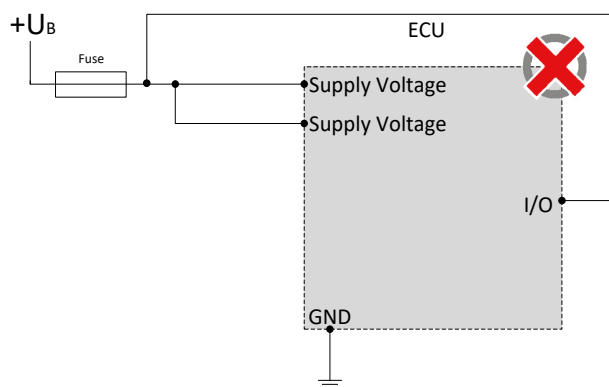
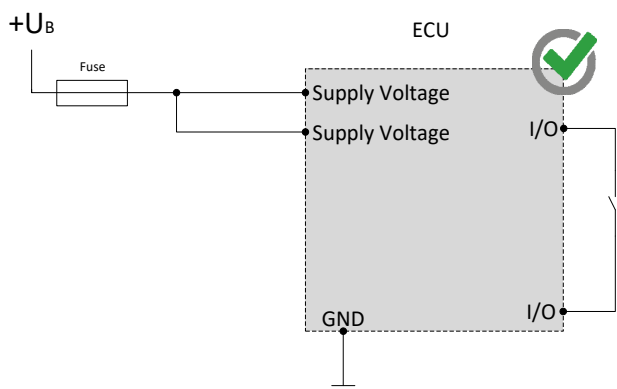

WIRING AND CABLE ROUTING RECOMMENDATIONS

Hightside outputs may only be switched to ground.

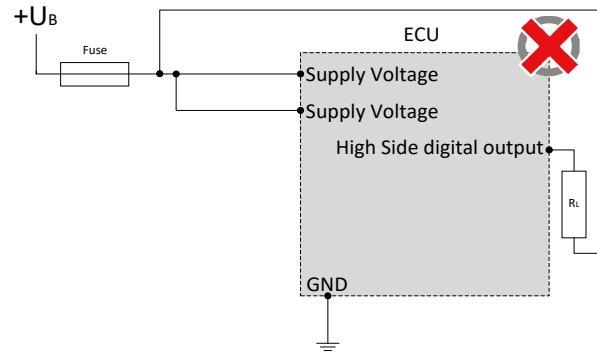
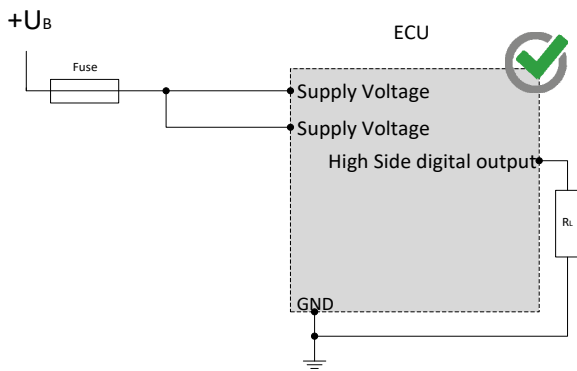
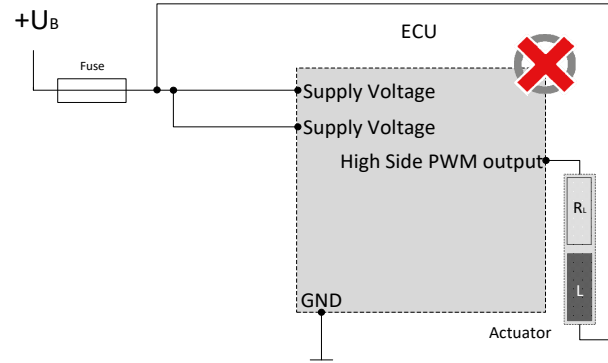
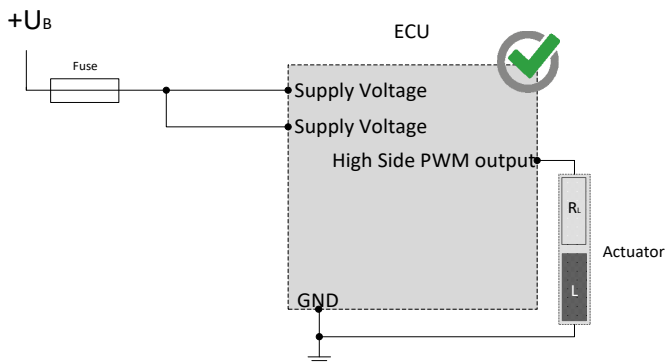

The CAN bus communication is the main communication between the control unit and the vehicle. Therefore, connect the CAN bus with special care and check the correct communication with the vehicle to avoid undesired behavior.

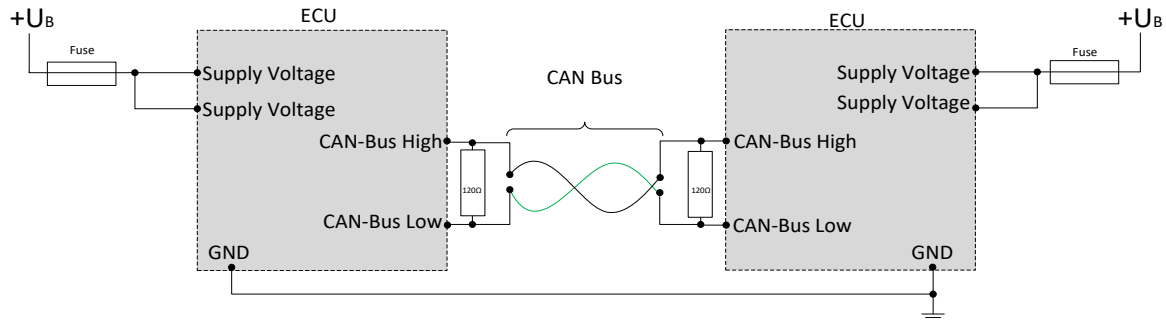

To comply with the IP protection class, the wiring harness attached to the mating connector must be routed through the cable harness sheath and the mating connector must be connected to the control unit. The cover included in the connector kit must then be closed over the mating connector. The cable harness sheath must be secured in the groove in the cover using cable ties.

SAFETY AND INSTALLATION INFORMATION

It is essential to read the instructions in full thoroughly before working with the device.

Please note and comply with the instructions in the operating instructions and the information in the device data sheet, see www.mrs-electronic.de

Staff qualification: Only staff with the appropriate qualifications may work on this device or in its proximity.

SAFETY



WARNING! Danger as a result of a malfunction of the entire system.

Unforeseen reactions or malfunctions of the entire system may jeopardise the safety of people or the machine.

- Ensure that the device is equipped with the correct software and that the wiring and settings on the hardware are appropriate.



WARNING! Danger as a result of unprotected moving components.

Unforeseen dangers may occur from the entire system when putting the device into operation and maintaining it.

- Switch the entire system off before carrying out any work and prevent it from unintentionally switching back on.
- Before putting the device into operation, ensure that the entire system and parts of the system are safe.
- The device should never be connected or separated under load or voltage.



CAUTION! Risk of burns from the housing.

The temperature of the device housing may be elevated.

- Do not touch the housing and let all system components cool before working on the system.

PROPER USE

The device is used to control or switch one or more electrical systems or sub-systems in motor vehicles and machines and may only be used for this purpose. The device may only be used in an industrial setting.



WARNING! Danger caused by incorrect use.

The device is only intended for use in motor vehicles and machines.

- Use in safety-related system parts for personal protection is not permitted.
- Do not use the device in areas where there is a risk of explosion.

Correct use:

- operating the device within the operating areas specified and approved in the associated data sheet.
- strict compliance with these instructions and no other actions which may jeopardise the safety of individuals or the functionality of the device.

Obligations of the manufacturer of entire systems

It is necessary to ensure that only functional devices are used. If devices fail or malfunction, they must be replaced immediately.

System developments, installation and the putting into operation of electrical systems may only be carried out by trained and experienced staff who are sufficiently familiar with the handling of the components used and the entire system.

It is necessary to ensure that the wiring and programming of the device does not lead to safety-related malfunctions of the entire system in the event of a failure or a malfunction. System behaviour of this type can lead to a danger to life or high levels of material damage.

The manufacturer of the entire system is responsible for the correct connection of the entire periphery (e.g. cable cross sections, correct selection/connection of sensors/actuators).

Opening the device, making changes to the device and carrying out repairs are all prohibited. Changes or repairs made to the cabling can lead to dangerous malfunctions. Repairs may only be carried out by MRS.

Installation

The installation location must be selected so the device is exposed to as low a mechanical and thermal load as possible. The device may not be exposed to any chemical loads.

Install the device in such a manner that the plugs point downwards. This means condensation can flow off the device. Single seals on the cables/leads must be used to ensure that no water gets into the device.

Putting into operation

The device may only be put into operation by qualified staff. This may only occur when the status of the entire system corresponds to the applicable guidelines and regulations.

FAULT CORRECTION AND MAINTENANCE



NOTE The device is maintenance-free and may not be opened.

- If the device has damage to the housing, latches, seals or flat plugs, it must be taken out of operation.

Fault correction and cleaning work may only be carried out with the power turned off. Remove the device to correct faults and to clean it.

Check the integrity of the housing and all flat plugs, connections and pins for mechanical damage, damage caused by overheating, insulation damage and corrosion. In the event of faulty switching, check the software, switches and settings.

Do not clean the device with high pressure cleaners or steam jets. Do not use aggressive solvents or abrasive substances.